

Palo Alto Research Center

Alto: A personal computer

**By C.P. Thacker, E.M. McCreight,
B.W. Lampson, R.F. Sproull, and D.R. Boggs**

XEROX

Alto: A personal computer

by C. P. Thacker, E. M. McCreight, B. W. Lampson,
R. F. Sproull, and D. R. Boggs

CSL-79-11 August 7, 1979

© Copyright 1979 by Xerox Corporation.

Abstract: The Alto is a small computer system designed in early 1973 as an experiment in personal computing. Its principal characteristics, some of the design choices that led to the implementation, and some of the applications for which the Alto has been used are discussed.

This paper will appear in Siewiorek, Bell and Newell, *Computer Structures: Readings and Examples*, second edition.

CR Categories: 6.21, 8.2

Key words and phrases: personal computer, graphics, local network

XEROX

PALO ALTO RESEARCH CENTER
3333 Coyote Hill Road / Palo Alto / California 94304

1. Introduction

During early 1973, the Xerox Palo Alto Research Center designed the Alto computer system ("Alto") as an experiment in personal computing, to study how a small, low-cost machine could be used to replace facilities then provided only by much larger shared systems. During the succeeding six years, the original Alto underwent several engineering enhancements to increase its memory capacity and reduce its cost, but the basic capabilities of the system have remained essentially unchanged. There are now (summer 1979) nearly a thousand Altos in regular use by computer science researchers, engineers, and secretaries.

The primary goal in the design of the Alto was to provide sufficient computing power, local storage, and input-output capability to satisfy the computational needs of a single user. The standard system includes:

- An 875 line raster-scanned display.
- A keyboard, "mouse" pointing device with three buttons, and a five-finger keyset.
- A 2.5 Mbyte cartridge disk file.
- An interface to the Ethernet system ("Ethernet"), a 3 Mbit/second communication facility.
- A microprogrammed processor that controls input-output devices and supports emulators for a number of instruction sets.
- 64K 16-bit words of semiconductor memory, expandable to 256K words.

All of these components with the exception of the user terminal are packaged in a small cabinet which is an unobtrusive addition to a normal office. The terminal, keyboard, and pointing device are packaged for desktop use (Figure 1).

The Alto has led to an entirely new computing environment. Many applications devote the entire machine to interacting with a user and satisfying his needs; examples are document production and illustration, interactive programming, animation, simulation, and playing music. These individual applications are supplemented by a large number of services available via communications; examples are printing service, mailbox services for delivering electronic mail, and bulk file storage services. The Ethernet has also given rise to applications that use several Altos concurrently to furnish additional computing power or to allow several people at their machines to interact with one another.

The principal characteristics of the Alto processor are described in Section 2. Sections 3 to 6 describe input-output controllers for the display, disk, Ethernet, and printer. Section 7 surveys the environment and applications that grew up for the Alto. Section 8 offers a brief retrospective look at the design.



Figure 1. The Alto personal computer, showing a user at work with the display, mouse, and keyset.

2. The Alto processor

The major applications envisioned for the Alto were interactive text editing for document and program preparation, support for the program development process, experimenting with real-time animation and music generation, and operation of a number of experimental office information systems. The hardware design was strongly affected by this view of the applications. The design is biased toward interaction with the user, and away from significant numerical processing; there are extensive user input-output facilities, but no hardware for arithmetic other than 16-bit integer addition and subtraction.

The processor is microcoded, which permitted the machine to start out with rather powerful facilities, and also allows easy expansion as new capabilities are required. The amount of control store provided has evolved over time as shown in Figure 2. Initially, the machine contained only 1K words, implemented with PROM. The most recent version provides 4K words, of which 1K is implemented with PROM, and 3K is RAM.

Year	Main Memory		Control Memory		Processor Memory	
	Size	Technology	Size	Technology	Size	Technology
1973	64K Parity	1K x 1 Dynamic Metal gate PMOS	1K PROM	256 x 4 Schottky bipolar	32 R registers	16 x 4 Schottky bipolar
1974			1K PROM 1K RAM			
1975	64K Error Correction	4K x 1 Dynamic Si gate NMOS	2K PROM 1K RAM	1K x 4 PROMs Schottky bipolar RAM as above		
1976						
1977	256K Error Correction	16K x 1 Dynamic Si gate NMOS	1K PROM 3K RAM	PROM as above 4K x 1 RAMs Static NMOS	32 R registers 8 x 32 S registers	R regs as above 256 x 4 Schottky bipolar
1979						

Figure 2. Sizes and technologies used for the principal memories in the Alto.

The micromachine is shared by sixteen fixed priority *tasks*. The emulator, which interprets instructions of the user's program, is the lowest priority task; the remaining tasks are used for the microcoded portions of input-output controllers and for housekeeping functions. Control of the micromachine typically switches from one task to another every few microseconds, in response to *wakeup requests* generated by the I/O controllers. The emulator task requests a wakeup at all times, and runs if no higher priority task requires the processor. There is usually no overhead associated with a task switch, since the microprogram counters (MPCs) for all tasks are stored in a special high speed RAM, the MPC RAM. The main memory is synchronous with the processor, which controls all memory requests.

The task switching mechanism provides a way of multiplexing all the system resources, both processor and memory cycles, among the consumers of these resources. In most small systems with single-ported memories, the *memory* is multiplexed among the I/O controllers and the CPU, and when an I/O controller is accessing the memory, the CPU is idle. In the Alto, the *processor* is multiplexed, and multiplexing of the memory is a natural consequence. By sharing the hardware in this way, it has been possible to provide more capable logical interfaces to the I/O devices than are usually found in small machines, since the I/O controllers have the full processing capability and temporary storage of the micromachine at their disposal.

The standard Alto contains controllers for the disk, the display, and the Ethernet. The disk controller uses two tasks, the display and the cursor use a total of four tasks, and the Ethernet uses one task. In addition to the emulator task, there is a *timed task* that is awakened every 38 μ s, and a *fault task* that is awakened whenever a memory error occurs and is responsible for logging the error and generating an interrupt. The timed task refreshes the main memory, and maintains the real-time clock and an interval timer accessible from the emulator.

The main memory size of the Alto was initially 64K 16-bit words, implemented with 1K bit semiconductor RAM chips. As semiconductor technology improved, the memory size was increased, as shown in Figure 2. The initial version of the machine provided parity checking; later configurations employ single error correction and double error detection. Memory access time is 850ns (five microinstruction cycles), and either one or two words can be transferred during a single memory cycle. In machines with more than 64K, access to extended memory is provided via *bank registers* accessible to the micromachine; the standard instruction set and I/O controller microcode make use of the additional memory only in limited ways. The reason for this clumsy arrangement is that the lifetime of the Alto has been longer than originally anticipated, and the additional memory was an unplanned addition.

Because the machine was intended for personal use, protection and virtual memory facilities normally included to support sharing were omitted from the Alto.

The multitasking structure of the processor led to an extremely simple implementation. The processor is contained on five printed circuit boards, each of which contains approximately 70 small and medium-scale TTL integrated circuits. Each of the three standard I/O controllers occupy a board with about 60 ICs. The main memory uses 312 chips.

2.1 Emulators

There are emulators for several instruction sets, including BCPL [Richards], Smalltalk [Kay, Ingalls], Lisp [Deutsch], and Mesa [Mitchell *et al.*]. The BCPL emulator is contained in the PROM microstore, while the others are loaded into RAM as needed. The BCPL instruction set was chosen because it is straightforward to implement and because we had previously developed a BCPL compiler for a similar instruction set. BCPL is a typeless implementation language; it has much in common with its well-known descendant, C [Ritchie *et al.*]. The language was used extensively to build Alto software; very little assembly language code has been written for the Alto.

The BCPL instruction set and the virtual machine it provides are summarized in Figure 3. Instructions are divided into four groups:

M-Group instructions transfer 16-bit words between memory and one of the four accumulators AC0-AC3. These instructions provide four indexing modes, and one level of indirection is allowed. The effective address is a 16-bit quantity, allowing access to a 64K word address space.

J-Group instructions include unconditional and subroutine jumps, and two instructions that increment and decrement a memory location and test the resulting value for zero. The effective address for these operations is calculated in the same way as for the M-Group.

A-Group instructions provide register-to-register arithmetic operations, shifts by one or eight places, and conditional skips based on the result of the operation.

S-Group instructions provide a number of functions that do not fit within the framework of the first three groups. Instructions are provided for loading, reading, and transferring control to special microcode in the writeable microstore, operating the real time clock and interval timers, optimizing BCPL procedure calls, accessing the extended memory, and maintaining specialized data structures used by the display.

The BCPL emulator provides a vectored interrupt system with 16 interrupt channels. There is no hardware support for interrupts; they are implemented entirely in microcode. (Note that the interrupt system is completely separate from the task-switching mechanism; the latter multiplexes the micromachine, while the former multiplexes the emulator.) When the microcode associated with an I/O controller wishes to cause an interrupt, it ORs one or more bits into a micromachine register NIW (New Interrupts Waiting). If the *i*-th bit of NIW is set, an interrupt on channel *i* is requested. At the start of every macroinstruction, NIW is tested; if it is nonzero, and if the corresponding channel is active, the emulator's macroprogram counter is saved in a fixed location in main memory and control is transferred to a location taken from a sixteen word table that starts at a fixed location. Individual channels are made active by setting bits in another fixed location. There are S-group instructions to enable and disable the entire interrupt system, and to return control from an interrupt routine.

M-Group

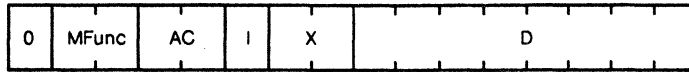

1: $AC \leftarrow MEM[EfAd]$
 2: $MEM[EfAd] \leftarrow AC$

Effective Address Calculation:

$EfAd \leftarrow \text{selecton } X \text{ into:}$

- case 0: D
- case 1: PC + sign extended D
- case 2: AC2 + sign extended D
- case 3: AC3 + sign extended D

if I # 0 then $EfAd \leftarrow MEM[EfAd]$

J-Group

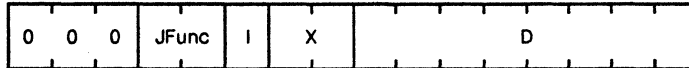

- 0: $PC \leftarrow EfAd$ (Jump)
- 1: $Ac3 \leftarrow PC + 1, PC \leftarrow EfAd$ (Jump To Subroutine)
- 2: $MEM[EfAd] \leftarrow MEM[EfAd] + 1$, if $MEM[EfAd] = 0$ then Skip
- 3: $MEM[EfAd] \leftarrow MEM[EfAd] - 1$, if $MEM[EfAd] = 0$ then Skip

A-Group

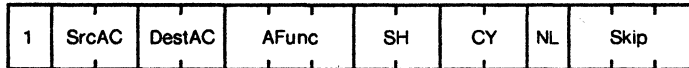

Afunc:

- 0: $DestAc \leftarrow NOT SrcAc$
- 1: $DestAc \leftarrow - SrcAc$
- 2: $DestAc \leftarrow SrcAc + 1$
- 3: $DestAc \leftarrow SrcAc$
- 4: $DestAc \leftarrow DestAc + SrcAc$
- 5: $DestAc \leftarrow DestAc - SrcAc$
- 6: $DestAc \leftarrow DestAc \cdot SrcAc - 1$
- 7: $DestAc \leftarrow DestAc AND SrcAc$

Shift:

- 0: -
- 1: LHS 1
- 2: RSH 1
- 3: Byte Swap

Cin ←

- 0: Carry
- 1: 0
- 2: 1
- 3: Carry'

Skip if:

- 0: Never
- 1: Always
- 2: $Result = 0$
- 3: $Result \neq 0$
- 4: $Result = 0$
- 5: $Result \neq 0$
- 6: $(Result = 0) OR (Cresult = 0)$
- 7: $(Result \neq 0) AND (Cresult \neq 0)$

S-Group

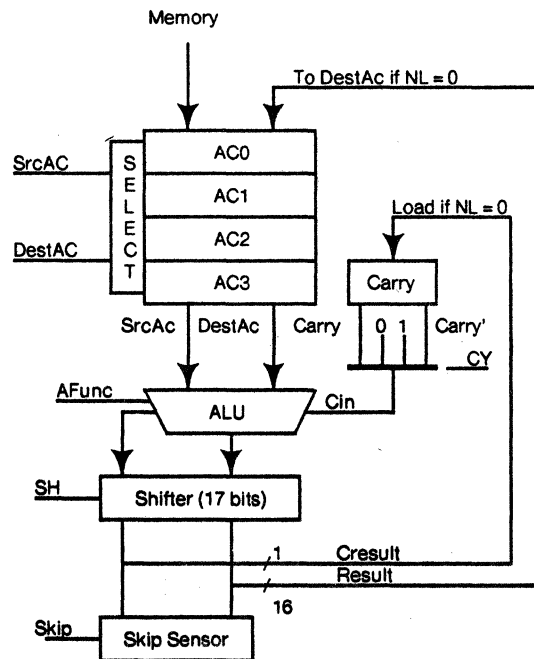
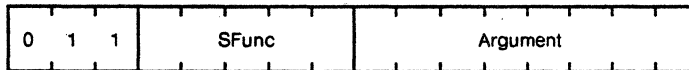

Figure 3. Summary of the BCPL instruction set and its virtual machine.

2.2 Input-output

I/O devices may be connected to the Alto in one of three ways, depending on the bandwidth required by the device and on the degree to which the controller is supported by specialized microcode. The three methods of connection and the level of the machine used to interface the hardware are summarized in the matrix of Figure 4.

		LOGICAL INTERFACE LEVEL		
		BCPL or Asm (Loads&Stores)	Emulator or Timed Task Microcode	Private Task Microcode
P H Y S I C A L C O N N E C T I O N S	Parallel I/O Port	Impact printer Prom programmer CPU debugger XY input tablet Cassette Tape	Stitch welder Low speed raster scanner raster printer	
	Memory Bus	Keyboard * Keyset * Console computer	Terminal concentrator Modem interface	Medium speed raster scanner Console computer
	Processor Bus		Mouse * Hardware Multiplier	Display * Disk * Ethernet * Arpanet 9 Track Tape High speed raster printer Audio Modem interface

* Included in standard Alto

Figure 4. Schematic illustration of input/output attachments used on the Alto.

Device controllers that require significant bandwidth, or exploit the computational facilities of the micromachine, are connected directly to the processor bus, and use one or more of the sixteen microcode tasks. The disk, display, and Ethernet controllers, which are part of the standard Alto, are interfaced in this way. The controller for a high-speed raster-scanned printer is an example of a non-standard I/O controller interfaced directly to the processor bus. These devices are described in detail in later sections.

Processor bus devices have one or more dedicated tasks that provide processing and initiate all memory references for the device controller; the tasks communicate with programs through fixed locations and data structures in main memory, and through interrupts. By convention, the second page of the address space is reserved for communication with devices of this type. Since there is only one processor, data structures shared between I/O controllers and programs can be interlocked by simply not allowing task switches in critical sections of device control microcode.

The amount of data buffering in a device controller, its task priority, and the bandwidth of the device trade off much as they do in systems which have DMA controllers competing for memory access. The controller must have enough buffering so that the wakeup latency introduced by higher priority devices will not cause the buffer to over- or underrun before it can obtain service. The disk, for example, has only one word of buffering ($10\mu\text{s}$ at 1.5Mbits/sec), and is therefore the highest priority task. The Ethernet requires more bandwidth, but since it has a 16-word buffer, it can tolerate much greater latency than the disk ($87\mu\text{s}$ at 3Mbits/sec), and hence runs at low priority. The display requires the highest bandwidth but it also has a 16-word buffer, so it can tolerate slightly more latency than the disk ($12.8\mu\text{s}$ at 20 Mbits/sec), and is therefore between the disk and Ethernet in priority.

It is also possible to connect a device directly to the processor bus without using a separate task. The microcode of the timed task, normally used to refresh the memory, may be modified to operate devices that require periodic service. When this is done, the timed task microcode is run in the writeable microstore. The mouse, a pointing device that provides relative positioning information by being rolled over a work surface, is operated by the timed task. At $38\mu\text{s}$ intervals, the mouse is interrogated for changes in position, and two memory locations corresponding to the mouse x and y coordinates are incremented or decremented when a change occurs. Specialized devices may also be operated directly by the emulator microcode; a hardware multiplier is an example of this type of device. An S-group instruction is added in the writeable microstore that loads the registers of the multiplier from the ACs, initiates the desired operation, and copies the results back into ACs when the operation terminates.

Devices with less demanding bandwidth requirements, or with computational requirements that can be satisfied by an emulator program rather than by a microprogram, are interfaced to the memory bus of the Alto. The advantage of this method is that no special microcode is needed. Communication between the hardware and a program is done using ordinary memory reference instructions, as in the PDP-11. The device controller decodes the memory address lines and delivers or accepts data under control of a read/write signal generated by the processor. The last two 256-word pages of the address space are reserved by the hardware for this purpose. Since a memory access requires five microinstruction cycles, these devices cannot transfer data as rapidly as those connected directly to the processor bus, where the transfer is controlled by the microinstruction and requires only one cycle. In the standard Alto, the keyboard and keyset are examples of devices handled in this way.

It is also possible to provide special microcode for devices that interface to the memory bus. A network gateway that connects 64 300-baud communication lines to the Ethernet has been implemented in this way. The scanner hardware consists of a single bit of buffering for the output lines, and level conversion for the input lines. Serialization and deserialization of eight-bit characters is done by microcode that is a part of the timed task; characters are passed to a macroprogram via queues maintained in main memory by this microcode. The macroprogram implements the higher level communication protocols.

The standard Alto provides a third method of connecting simple devices, the *parallel I/O port*. This is a memory bus device, and consists of a single 16-bit register that can be loaded by a *store* instruction, and a set of 16 input lines that can be read by a *load* instruction. The device controller does not occupy a card slot in the backplane, but is external to the machine, and attaches via a cable to a standard connector on the back of the machine, which in turn is wired to the memory control board. A large number of devices have been connected to the Alto through this simple interface, including low speed impact printers, a PROM programmer, a stitchwelding machine for the fabrication of circuit boards, and several types of low-speed raster printers. Most devices that use speed-insensitive handshake protocols can be interfaced via the parallel I/O port; such devices require neither specialized hardware nor microcode.

2.3 Details of the micromachine – control

The microinstruction format of the Alto is shown in Figure 5, and the principal data paths and registers of the micromachine are shown in Figure 6. Each microinstruction specifies:

- The source of processor bus data (BS).
- The operation to be performed by the ALU (ALUF).
- Two special functions controlled by the F1 and F2 fields.
- Optional loading of the T and L registers (LT, LL).
- The address of the next microinstruction (NEXT).

All microinstructions require one clock cycle (170ns) for their execution. If a microinstruction specifies that one or more registers are to be loaded, this happens at the end of the cycle.

The Alto does not have an incrementing microprogram counter. Instead, each microinstruction specifies the least significant ten bits of the address of its successor using the NEXT field in the instruction. This successor address may be modified by the branch logic or by the I/O controllers. There are special functions to switch banks in the microstore, allowing access to the entire 4K address space. The address of the next microinstruction to be executed by each of the 16 tasks supported by the micromachine is contained in the 16-word MPC RAM. This RAM is addressed by the NTASK register, which contains the number of the task that will have control of the processor in the next cycle. The MPC RAM value for the current task is updated every microinstruction cycle.

Execution of a microinstruction begins when the instruction is loaded into the Microinstruction Register (MIR) from the control store outputs. At this time, the information on the NEXT bus is written into the MPC RAM at the location addressed by the NTASK register. This value is the address of the next instruction; within a short time, it appears at the output of the MPC RAM, the next instruction is fetched from the control store, and the cycle repeats.

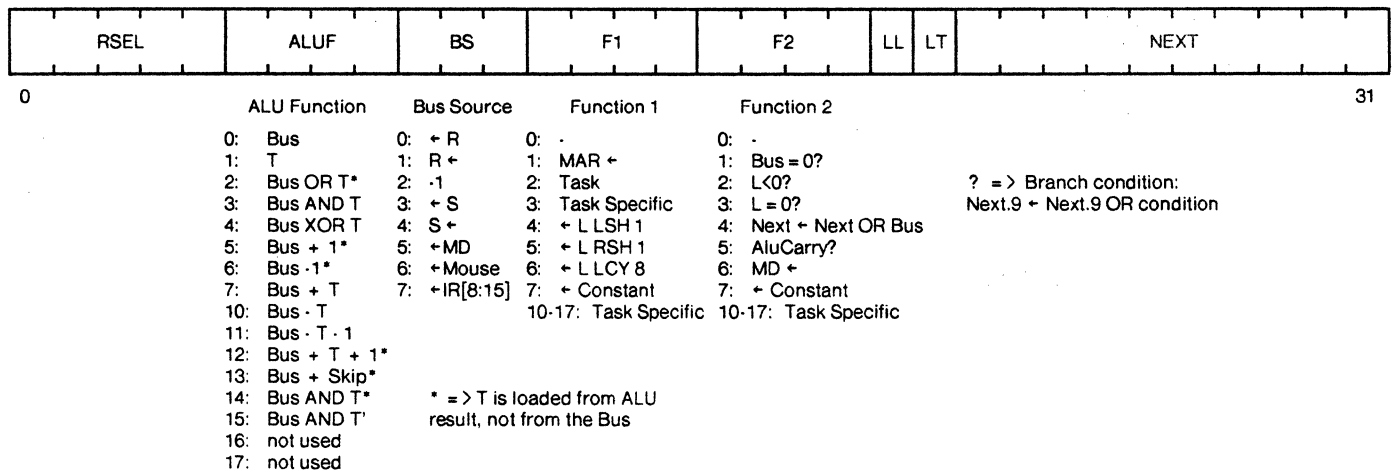

Figure 5. Alto microinstruction format.

Conditional branches are implemented by ORING one or more bits with the NEXT address value supplied by the control store. The source of the data to be ORed is usually specified by the F2 field; it may be a single bit, for example the result of the BUS=0 test, or it may be several bits supplied on the NEXT bus by an I/O controller or by specialized logic. When the value consists of an n-bit field, a 2^n -way branch, or *dispatch* is done. Because the next instruction is already being fetched while the instruction is being executed, conditional branches and dispatches affect not the address of an instruction's immediate successor, but the instruction following that one. It is possible to execute branches in successive instructions, providing this pipelining is taken into account by the microprogrammer. This branching scheme constrains the placement of instructions in the microstore, but the constraints are satisfied semi-automatically by the microprogram assembler.

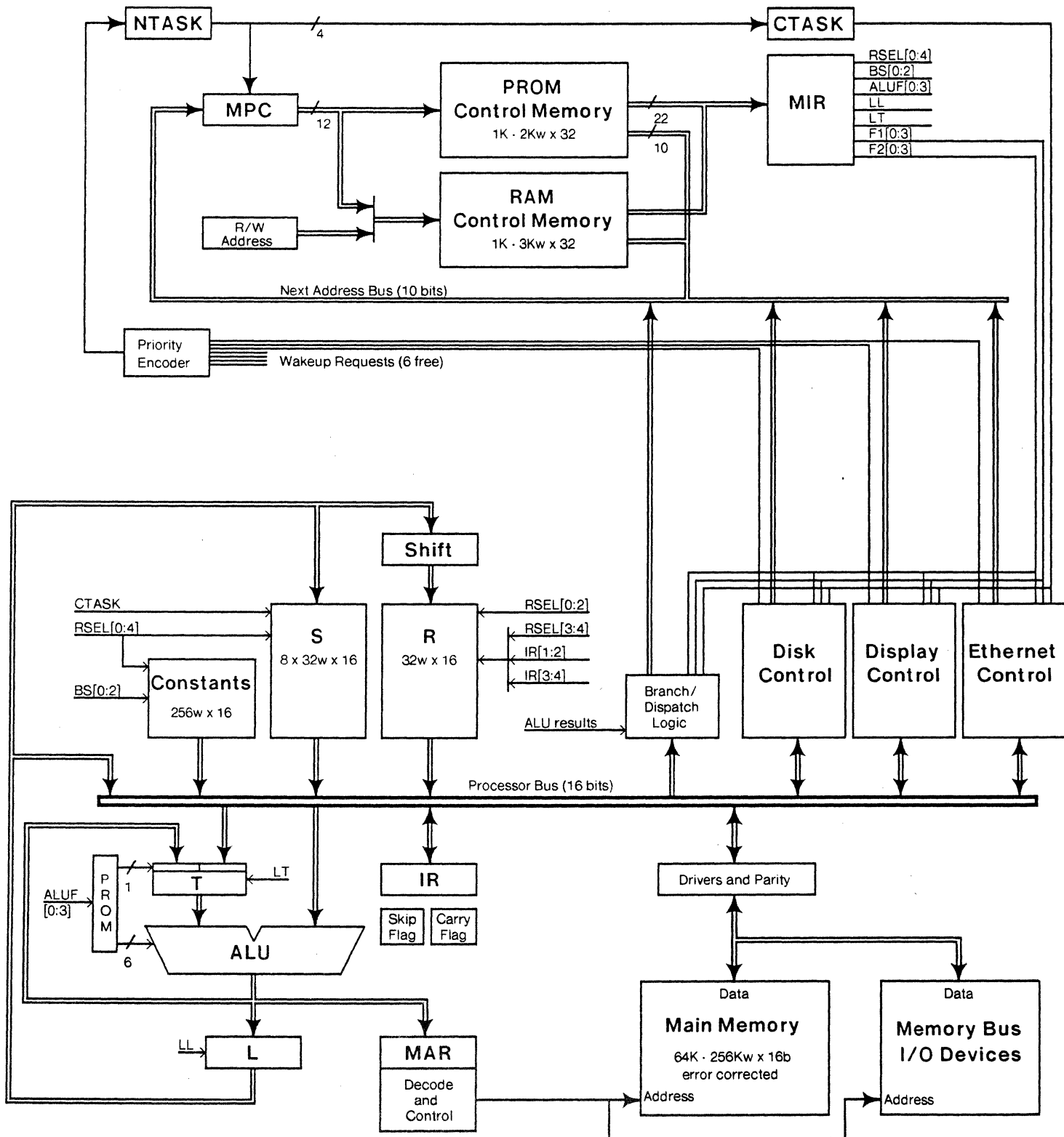

Figure 6. Alto micromachine structure.

Task switching in the Alto is done by changing the value in the NTASK register. As long as the value in this register does not change, a task will remain in control of the processor. A task gives up control of the processor by executing a microinstruction containing F1=TASK. This function loads the NTASK register from the output of a priority encoder whose inputs are the 16 *wakeup request* lines, one per task. An I/O controller indicates its need for service from the processor by asserting the request line associated with its task. If it is the highest priority requester when the running microprogram executes the TASK function, NTASK will be loaded with its task number; after a one instruction delay, the new task will acquire the processor. In the microinstruction following a TASK, a microprogram may not execute a conditional branch, and it must not allow a task switch when it has state in the L or T registers, since none of the state of a task other than the MPC value is saved across a task switch. With these exceptions, there is no overhead associated with task switching.

The conditions that cause I/O controllers to request wakeups are determined by the controller hardware, and are usually simple—an empty buffer requires data, or a sector pulse has been received by the disk controller, for example. When the microcode associated with the controller has processed the request and commanded the controller to remove the wakeup request, the microprogram then TASKs, relinquishing control of the processor.

By convention, eight of the possible values of the F1 and F2 fields of the microinstruction are *task-specific*; that is, they have different meanings depending on which task is running. Each I/O controller can determine when its associated task has control of the processor by decoding the NTASK lines. When the task associated with a controller is running, the controller decodes the F1 and F2 lines and uses them to control data transfers, to specify branch conditions, or for other device-specific purposes. This encoding reduces the size of the microinstruction.

The intimate coupling between the micromachine and the I/O controllers has proven to be one of the most powerful features of the Alto. When a new I/O device is added, the controller not only has at its disposal the basic arithmetic and control facilities of the micromachine, but it can also implement specialized functions controlled by the task-specific function fields of the microinstruction. This has led to extremely simple hardware in the I/O controllers. Most controllers consist of a small amount of buffering to absorb wakeup latency, registers and interface logic to implement the electrical protocols of the device, and a small amount of logic to decode the F1 and F2 lines, generate wakeups, and do whatever high speed housekeeping is required by the device. Since the processor makes all the memory requests, controllers never manipulate memory addresses, and the usual DMA hardware found in most minicomputers is eliminated.

It might appear that sharing the processor in this way would result in a significant degradation in performance, particularly for low priority tasks such as the emulator. This is in fact not the case; *the major bottleneck in the system is the memory*. Since most computation can be overlapped with memory operation, the performance of the Alto compares favorably with other systems employing single-ported, non-interleaved memory at comparable I/O bandwidths.

2.4 Details of the micromachine—arithmetic

The arithmetic section of the Alto contains the following components:

A 16-bit processor bus, used to transmit data between the subsections of the processor, the memory, and the I/O controllers. The source of bus data is controlled by the BS and the F1 fields of the instruction.

A bank of 32 16-bit *R registers*, and eight banks of 32 16-bit *S registers*. These registers have slightly different properties, and together constitute the high speed storage of the processor. As better integrated circuit technology has become available, the number of S registers has been increased as shown in Figure 2. R and S are addressed by the RSEL field of the instruction; either R or S (but not both) can be used during a single instruction. Reading and loading of R and S are controlled by the BS field of the instruction.

A 16-bit T register. T is loaded when the LT bit is set in the microinstruction. The source of T data is determined by the ALU function being executed; it is usually the bus, but may be the output of the ALU. T is one of the inputs of the ALU.

A 16-bit Arithmetic/Logic Unit (ALU). The ALU is implemented with four SN74S181 ICs. These devices can provide 64 arithmetic and logical functions, most of which are useless. The fourteen most useful functions are selected by the four bit ALUF field of the microinstruction, which is mapped by a PROM into the control signals required by the chips.

A 16-bit L register. L is loaded from the ALU output when the LL bit is set in the microinstruction.

A shifter capable of shifting the data from L left or right by one bit position and exchanging the two halves of a word. Simple shifts are controlled by the F1 field of the instruction (F1=4, 5, 6). In the emulator task, these functions may be augmented by the F2 field to do specialized shifts required by the BCPL instruction set, and to do double-length shifts for microcoded multiply and divide.

A 16-bit Memory Address Register (MAR), described later.

A 256 word by 16-bit constant memory, implemented with PROMS. This memory is addressed by the concatenation of the RSEL and BS fields of the instruction; when F1 or F2=CONSTANT, the normal actions evoked by RSEL and BS are suppressed, and the selected constant is placed on the bus. Approximately 200 of the 256 available constants have been used.

An Instruction Register (IR) that holds the current macroinstruction being executed by the BCPL emulator.

The main memory is synchronous with the processor, which initiates all memory references by loading MAR with the 16-bit address of a location. During a memory reference, data may be transferred between the memory and any register connected to the bus, including registers in the I/O controllers. The memory can transfer a doubleword quantity during two successive instruction cycles, as part of a single memory cycle. Using this access method, which was provided to support high performance peripherals such as the display, the peak memory bandwidth is $32\text{bits}/(6 \cdot 170\text{ns}) = 31.3 \text{ Mbits/sec}$.

The arithmetic section of the Alto contains a small amount of hardware to support the emulator for the BCPL instruction set. There are special paths to supply part of the R address from the SrcAC and DestAC fields of IR, logic to dispatch on several fields in IR, and hardware to control the shifter and maintain the CARRY and SKIP flags. The total amount of specialized hardware is less than ten ICs.

No special hardware has been added to support emulators for other instruction sets. These usually specify the operation to be performed with a single eight-bit byte, followed by one or two bytes that supply additional parameters for some of the operations. The standard dispatching mechanism is used to do an initial 256-way dispatch to the microcode that emulates each macroinstruction.

The dispatching mechanism has been used for other applications. Although the micromachine does not support subroutine linkage in the hardware, it has been possible to achieve the same effect with only a small performance penalty. The calling microcode supplies a small constant as a *return index* (typically in T) which is saved and used as a dispatch value to return to the caller when the subroutine has completed its work. The Mesa emulator implements an eight word operand stack by dispatching on the value of the stack pointer into several tables of eight microinstructions, each of which reads or writes a particular R-register.

The parallelism available in the microinstruction format encourages the use of complex control structures which are often substituted for specialized data handling capabilities; it is usually possible to do an arithmetic operation, a branch or dispatch, and at least one special function in each instruction.

3. User input/output

The main goals in the design of the Alto's user input/output were generality of the facilities and simplicity of the hardware. We also attached a high value to modeling the capabilities of existing manual media; after all, these have evolved over many hundreds of years. There are good reasons for most of their characteristics, and much has been learned about how to use them effectively. The manual media we chose as models were paper and ink (the display), pointing devices (the mouse and cursor), and keyboard devices ranging from typewriters to pianos and organs.

3.1 *The display*

The most important characteristic of paper and ink is that the ink can be arranged in arbitrarily chosen patterns on the paper; there are almost no constraints on the size, shape or position of the ink marks. This flexibility is used in a number of ways:

Characters of many shapes and styles not only represent words, but convey much important information by variations in size and appearance (italics, boldface, a variety of styles).

Straight lines and *curves* make up line drawings ranging in complexity from a simple business form to an engineering drawing of an automatic transmission.

Textures and shades of gray, and *color*, are used to organize and highlight information, and to add a third to the two dimensions of spatial arrangement.

Halftones make it possible to represent natural images which have continuous tones.

Fine-grained *positioning* in two dimensions produces effects ranging from the simple (superscripts, marginal notes, multiple columns) to the complex (mathematical formulas, legends in figures).

The *high resolution* of ink, combined with the absence of positioning constraints, means that a large amount of information can be presented on a single page.

In addition to imaging flexibility, paper and ink have several other important properties:

Large sizes of paper can present the spatial relationships of many thousands of objects.

Many sheets of paper can be *spread out*, so that many pages can be wholly or partially visible.

Many sheets of paper can be *bound together*, so that one item from a very large collection of information can be examined within a small number of seconds.

Only one technique is known for approximating *all* these properties of paper in a computer-generated medium: a raster display in which the value of each picture element is independently stored as an element in a two-dimensional array called a *bitmap* or *frame buffer*. If the size of a picture element is small enough, such a display can approximate the first five properties extremely well; about 500-1000 binary (black or white) elements per inch are needed for high quality, or 25-100 million bits for a standard 8.5x11 inch page. Another approach (which we did not pursue) is to exploit the fact that unlike paper and ink, the display can provide true gray. If each picture element can assume one of 256 intensity values (or a triple of such values for color), almost all images which are made on paper can be reproduced with many fewer picture elements than are needed if the elements are binary; about 100-150 elements per inch are now sufficient, or 8-18 million bits for a page.

Even eight million bits of bitmap was more than we could afford in 1973. Furthermore, the computer display cannot hope to match paper in size, or in the number of pages which can be visible simultaneously. To make up for this deficiency, and to model page-turning, it is necessary to alter the image on the screen very rapidly, so that changes in the single screen image can substitute for changes in where the eye is looking and for the physical motion of paper. As the number of bits representing the image grows, more processing bandwidth is required to compose it at acceptable speeds.

Fortunately, surprisingly good images can be made with many fewer bits, if we settle for images which preserve the recognizable characteristics of paper and ink, rather than insisting on all the details of image quality. Characters 10 points or larger (these are printer's points, 72 per inch, and the characters in this sentence are 10 point) in several distinguishable styles and in boldface or italic, almost arbitrary line drawings, and dozens of textures are quite comfortable to read when represented by about 70 binary elements per inch; this resolution is also sufficient for crude but recognizable characters down to 7 points, and for halftones of similar quality. One page at this resolution is about half a million bits, or half of the Alto's one megabit memory.

The display is an interlaced 875 line monitor running at 30 frames/second. There are 808 visible scan lines, and 608 picture elements per line. It is oriented with the long dimension vertical, and the screen area is almost exactly the same size as a standard sheet of paper (Figure 7). Refreshing the display demands an *average* of 15 megabits/second of memory bandwidth. Since the average includes considerable time for horizontal and vertical retrace, the peak bandwidth is 20 Mbits/second. The 30 Hz refresh rate results in flicker which most people do not find objectionable, provided the image does not contain large amounts of detail which appears in only one of the two interlaced fields. Flicker is reduced by the use of a P40 phosphor in the CRT, rather than the faster P4 often used; the greater persistence of images which are being moved has not proved to be a problem.

OVERLAPPING

Overlapping, to be an effective tool, must first have all things in the picture roughly sketched as if they were transparent—as if you could see through them. The objects are first drawn as if they were made out of glass. By beginning with transparent objects it is easy to see if they have been correctly drawn. In the finished drawing all objects will be correctly drawn.

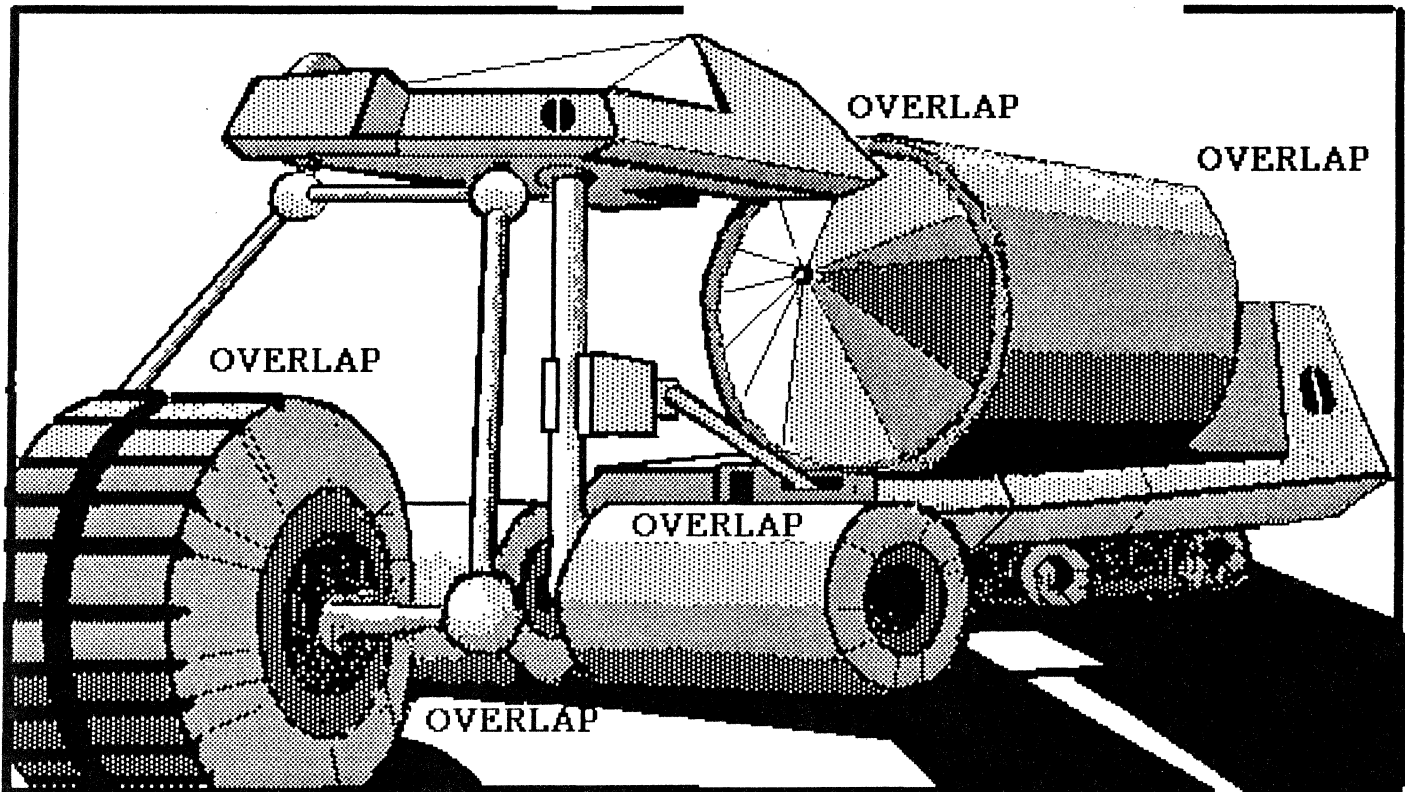

Figure 7. An example of text and graphics at Alto screen resolution.

3.2 Bitmap representation

A bitmap which can be painted on the display is represented in storage by a contiguous block of words. A bitmap on the Alto represents a rectangular image, w picture elements wide and h elements high. For simplicity, w must be a multiple of 16, and one row of w picture elements corresponds to $w/16$ contiguous words in the bitmap. As a consequence, two vertically adjacent elements correspond to the same bit in two words which are $w/16$ words apart in storage (Figure 8).

The display microcode interprets a chain of *display control blocks* stored in memory, with its head at a fixed location. Each block specifies its successor, the number of scan lines it controls, the left margin (in 16-element units) of the screen area to be painted from the bitmap in storage, the address and width of the bitmap array, and the *polarity*, which determines whether zeros in memory are displayed as white (the normal case) or black. The left and right margins not painted from the bitmap are filled with zeros. This scheme allows the screen to be divided into horizontal strips, each with its own bitmap; its advantages and drawbacks are discussed below.

To simulate an 8.5x11" page we use a single control block which covers all 808 visible scan lines, has no left margin, and is 608 bits (38 words) wide. This is a *full screen* bitmap; it consumes about half the main storage of the standard machine, and displaying it consumes about 60% of the cycles. In return, it can display nearly any image which can appear on a standard sheet of paper. More restricted images, however, can be displayed more economically. An ordinary text page like this one, for example, can be divided into horizontal strips. The white space in the margins, in indentations, and to the right of the last line in each paragraph need not appear in the bitmap. The leading between the paragraphs, and the margins at top and bottom, can be represented by control blocks specifying a width of zero. For a typical text page these tricks reduce the size of the bitmap to about 70% of its full size; pages of program listing are reduced by much more. Furthermore, lines can be inserted or deleted simply by splicing pointers in the control block chain, and parts of the image can be scrolled up or down by adjusting the number of scan lines covered by one of the zero-width control blocks, without moving anything in storage.

Unfortunately, these techniques rule out anything except a single column of text in the image, since various parts of the image no longer have any supporting bitmap. Multiple columns (unless the lines are perfectly aligned), marginal notes, long vertical lines, or windows which do not fill the screen horizontally are not possible. We have used multiple control blocks heavily in the Alto's standard text editor, which includes extensive facilities for using multiple fonts, controlling margins and leading, justification etc. The editor continuously displays the text in its final formatted form, so that no separate operations are required to view the final document. In this context the control block tricks have made it possible to fit the editor into the machine, which we could not have done using a full-screen bitmap. All the other interesting uses of the display, however, have adopted the full-screen bitmap so that they could support more general images, and we are convinced that the cost of memory is no longer high enough to justify giving up this generality.

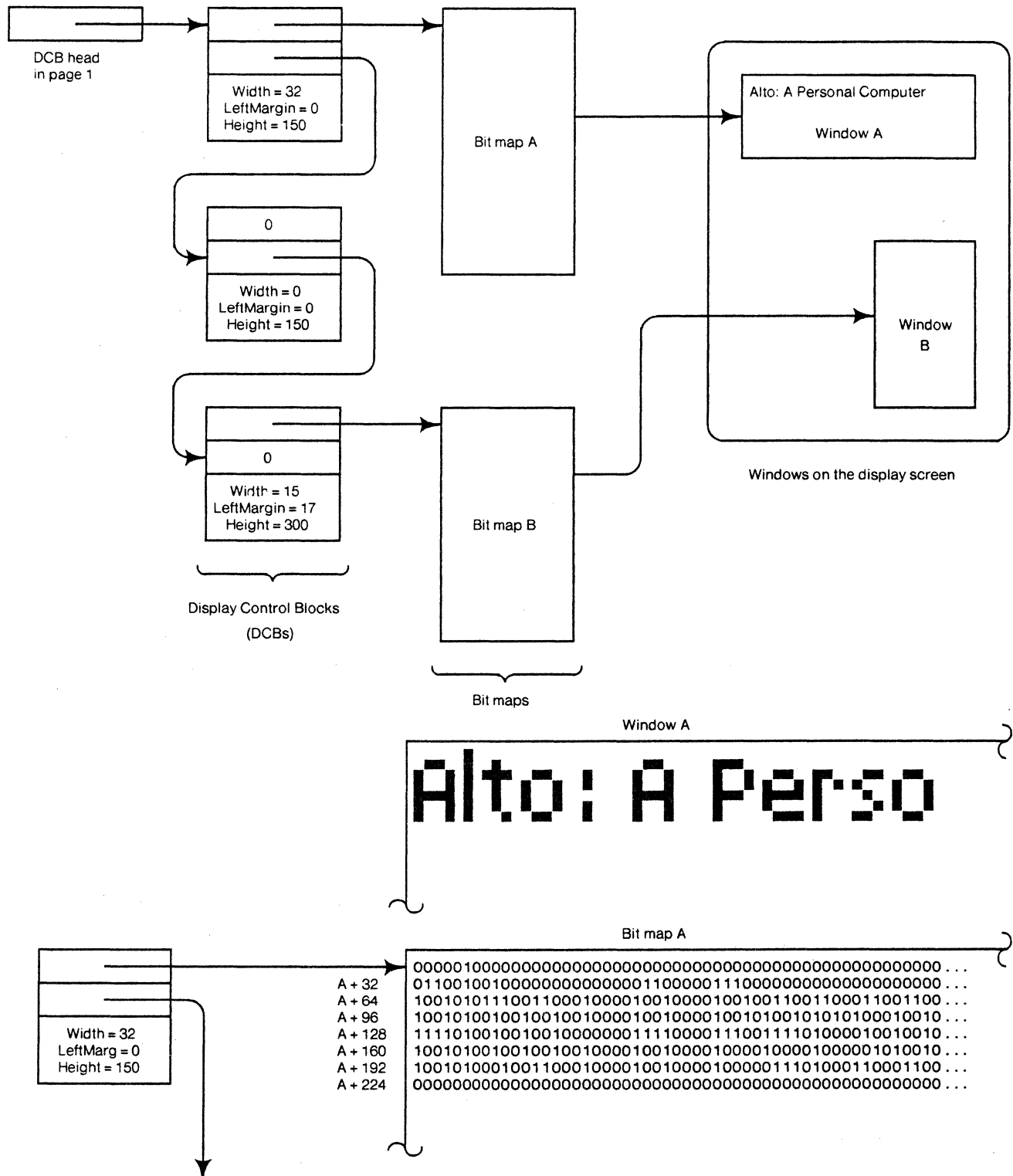

Figure 8. The display data structure and its mapping onto the screen. The top part of the figure illustrates several control blocks and the corresponding screen windows they control. The lower part shows the relation between a bitmap in memory and the image on the screen. Note that the pattern of 1's in the bitmap corresponds to the pattern of black dots on the screen.

3.3 Composing the image

Because many bits are needed to display an image, we have found the machine's ordinary data manipulation instructions inadequate for handling images. It is important to have fast ways of building up the most common kinds of images and making certain common changes (e.g., moving or scrolling a window). For this purpose the Alto has one major microcoded operation called BitBlit (for bit boundary block transfer), with a surprising number of uses. It works on *rectangles* within bitmaps; such a rectangle is defined by the width of the bitmap (which determines the spacing in storage of vertically adjacent elements), the address of the bit which corresponds to the upper left corner of the rectangle, and the height and width of the rectangle (in bits). BitBlit takes two such rectangles, called the *source* and the *destination*, and does

$$\text{destination} \leftarrow F(\text{destination}, \text{source})$$

where $F(d, s)$ can be s (move), d OR s (paint), d XOR s (invert) or d AND s (erase), or any of these with s complemented. It is also possible to supply a 16x4 rectangle for the source and have it used repetitively; this is useful for producing uniform textures. The properties of BitBlit, which was designed by Dan Ingalls, are discussed in more detail in [Newman-Sproull], where it goes under the name *RasterOp*.

BitBlit has a large number of applications, among them

Painting characters from a *font*, which is simply another bitmap, held somewhere in storage, that contains images of the characters. It is interesting to note that "characters" can also be used to represent various specialized kinds of graphics, such as the symbols in hardware logic drawings.

Drawing horizontal and vertical lines (which are just narrow rectangles).

Filling in rectangular areas with textured patterns.

Scrolling an image across a fixed rectangular window on the screen, or moving such a window around on the screen.

Moving an image onto the screen from a copy elsewhere in storage.

Saving part of the image in memory that is not part of the display bitmap. Later, the saved image can be copied back to cause it to reappear on the screen.

The Alto also has a specialized operation for painting characters; it is considerably less flexible than BitBlit, but easier to invoke and more efficient.

Sometimes one would also like fast operations for painting arbitrary lines and curves, and for filling solid areas bounded by such shapes, but so far we have not found the need for these to be great. Instead, these requirements are adequately met by the Alto's ordinary memory reference instructions, which can be used to randomly access and update the display with complete flexibility. We have found this to be quite important, and believe that it is a significant advantage of the Alto architecture over conventional frame-buffer organizations. The ability to reuse part or all of the bitmap memory for other purposes when a full-screen display is not required has also been very important; with the decreasing cost of memory this is no longer such a significant consideration.

3.4. Display hardware

This display is supported by three microcode tasks and some very simple hardware (Figure 9). Serial video data is clocked by a 50 ns bit clock; everything else is clocked by the machine's 170 ns main clock, which is chosen to be an integral submultiple (224) of the display's line rate ($875 \times 30 = 26.25$ kHz). A 16 word RAM and a one word register implement a FIFO buffer and synchronizer between the processor bus and the shift register which serializes data for the display. There is a sync generator with a counter and PROM for horizontal sync and one for vertical sync, and logic to wake up the *data task* whenever the FIFO is not full, the *line task* when horizontal blanking starts, and the *field task* when vertical blanking starts. There is also some logic to support the cursor described in section 3.5.

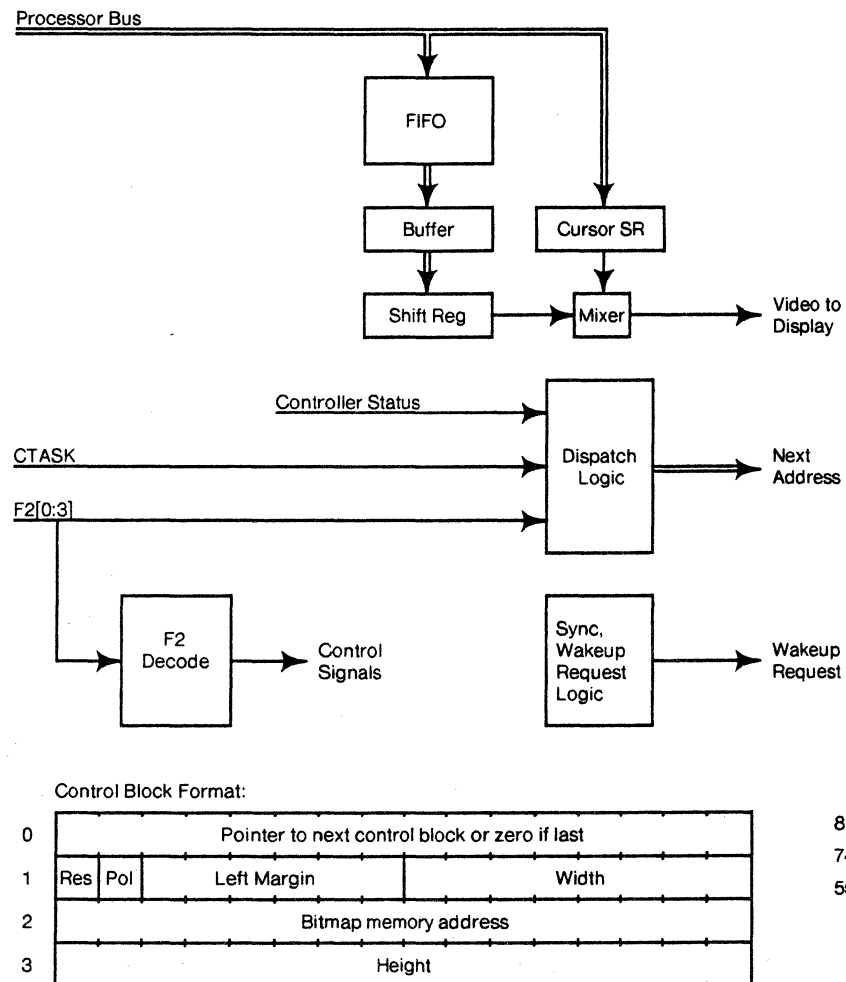

Figure 9. The display controller.

The field task runs 60 times a second, and is responsible for initializing the line task at the head of the chain of control blocks. It also generates a 60 Hz interrupt. The line task runs every 38 μ s; it initializes the left margin width, bitmap address and bitmap width for the data task, and advances to the next control block if the current one is exhausted. When no control blocks remain, it goes to sleep until reawakened by the field task. The data task outputs zeros until the left margin is exhausted, then fetches doublewords from storage and delivers them to the FIFO until the bitmap width is exhausted, after which it goes to sleep until reawakened by the line task. A doubleword fetch takes six cycles or 1.05 μ s, and the 32 bits are consumed in 1.6 μ s, so the data task consumes two thirds of the machine while data is being displayed (which is 73% of the time, the rest being spent in retracing).

3.5 Pointing

A user working interactively with images frequently points at parts of the image, to identify the spot where something should be done, to select a menu item, to indicate the corners of a region, etc. For this purpose the Alto has a device called a *mouse*, which fits comfortably under a hand and can be rolled around on the work surface [English *et al*]. The mouse is supported on three ball bearings, and the x and y rotations of one of these bearings are sensed by the Alto. The hardware senses motion by ± 1 increments in each direction (one unit is roughly 1/200 inch), and microcode running in the timed task uses this information to update a pair of *mouse coordinates* in storage. Often it is also nice to be able to draw, and the mouse can do this too, albeit somewhat clumsily. When drawing is important, a tablet is used, but this device interferes so much with the keyboard that it is not generally popular.

It is essential to have visual feedback which indicates the mouse position, since there is no direct visual or tactile connection between the mouse position and anything in the image on the screen. This feedback is provided by the *cursor*, which is a special 16x16 bitmap stored at a fixed place in memory, together with x and y coordinates that control where it is displayed. The cursor has its own microcode task, which runs after the display's line task and loads two hardware registers with the proper cursor data for the current scan line, and the x coordinate at which its first element should be displayed. The hardware starts shifting out the data when the display reaches the specified picture element, and it is ORED with the main display data. The connection between the mouse and the cursor coordinates is established entirely by software, which may, for example, restrict the cursor to some region of the screen, force it to move on a grid to facilitate lining things up, or make it "snap" onto sensitive points when it approaches close to them. Much use is made of the fact that the cursor image, though small (about 1/4" square), is programmable. This turns out to be extremely valuable, because the user is much more likely to be looking at the cursor than anywhere else on the screen. A remarkable variety of shapes can be represented on those 256 bits, and a great deal of important information easily and unintrusively conveyed.

Another important property of the mouse is the three buttons on its top surface. These allow the user to specify a number of commands using the same hand with which he is pointing, especially when the meanings of the buttons are modified by shift keys on the keyboard, or by taking account of the duration or frequency of clicks. The current state of each button (up or down) appears as three bits in a special memory location, so that the program is free to attach meaning to any detail of the user's interaction with the buttons.

3.6 Keyboard

The Alto has a standard office typewriter keyboard, augmented with a small number (8) of extra keys. The keyboard appears to the program as four words of memory; each of the bits in these words reflects the current state of one key (up or down). This allows any key to be used as a shift key, and as with the mouse, it permits a variety of non-standard interpretations of the keys to be programmed, ranging from repeating keys to a digital electronic organ manual.

4. Local storage

The Alto has a reasonably powerful and very reliable disk file system. This file system is implemented on a 2.5 megabyte moving-head removable-media rigid disk drive with which every Alto is equipped. All Alto software can read and write disk files, which are the usual interface among Alto software subsystems.

The disk controller consists of one board of special-purpose hardware, and a share of the Alto micromachine. The disk controller and the file system were designed together, so that the functions of the controller match the functions of the file system. Thus, certain file system functions are performed entirely by the disk controller to insure speed or reliability. These functions are easily implemented because the full power of the Alto processor is available to the controller.

4.1 File system

An Alto disk pack contains a set of disk files. A disk file is a sequence of bytes, identified by a serial number unique within the disk pack. The disk controller and the file system software together implement a set of operations to create, extend, truncate, or delete files, and to read or write sequences of bytes within a file. A file is implemented as a non-contiguous sequence of fixed-length pages recorded on the disk pack. Each page of a file except the last is completely full of data (Figure 10).

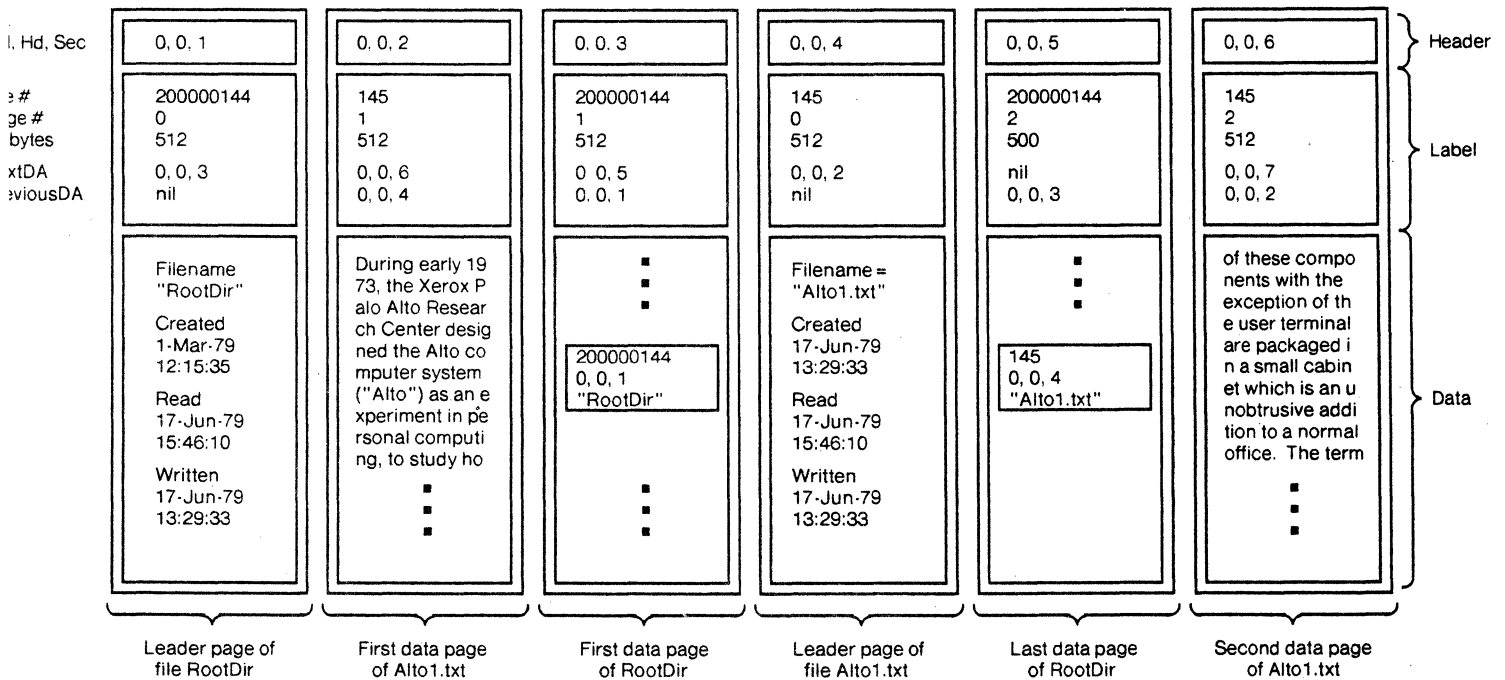

Figure 10. The Alto file system structure.

The Alto file system is designed to be reliable. Many file systems have the property that bad data on a single page may create such confusion that the good data on the rest of the disk is practically useless. To control the global damage that could result from localized errors, the Alto file system distributes structural information to each page on the disk. Each page contains a special record called the *label*, different from the data record, that says, for example, "I am now serving as page 17 of file number 34152." Page 0 of a file, the *leader page*, holds information about the file: its alphanumeric name, the date of last modification, and so on; actual data begins in page 1. The distributed structural information recorded in the label (serial number, page number, length) and in the leader page (name) is the basic file system data structure.

The basic data structure is supplemented by a set of *hints*, performance-improving assertions whose truth can easily be verified. Because it is inefficient to scan the entire disk to find the leader page of a given file, a *directory* file maintains hints about file locations. If the directory file says that page 0 of file number 3456 is located at disk address 7890, then before doing anything irreversible at disk address 7890, the disk controller checks whether the label record at that address admits to being page 0 of file 3456. To allow rapid access to a sequence of pages, each label records as hints the disk addresses of the immediately preceding and following pages of the file (Figure 10). If hints of any sort are found to be erroneous, they can be reconstructed from the distributed structural information. In fact, one of the most important programs on the Alto is the hint-reconstructing *Scavenger*.

The disk controller makes it easy to use hints properly, and to do other common file-system operations. A disk operation is invoked with a *command block*, a group of words in main memory that specify a disk address, a page buffer address in main memory, and the transfer operation to be performed (Figure 11). The disk controller is activated by putting the address of a command block into a particular main memory location. The controller performs the requested operation, writes the final status in the command block, and (if all went well) automatically proceeds to the next command block in a chain of blocks, linked by pointers. Disk command blocks are designed to be included in more complex operating system data structures describing pending disk transfers.

File system damage results as often from errant software as from errant hardware. The file system/disk controller design attempts to minimize damage in two ways. First, each disk command block is required to contain the *seal*, a certain exact bit pattern. The disk controller will stop immediately if it encounters an improper seal. Thus if the disk controller is accidentally activated on a block of memory that is not a legal disk command block, its seal would probably be improper, and file system damage would be avoided.

The second way to assure file system integrity is to check the label record before reading or writing, as mentioned earlier. Many disk controllers in other systems implement a header record for each page, separate from the data record, that is checked before reading or writing the data record. This strategy provides protection from failures of seeking or sector counting hardware, but not from software failures. An Alto disk sector incorporates separate header, label, and data records. The disk controller checks the header record to be sure the access hardware works, and then checks the

label record to be sure that the file system software works, before reading or writing a data record.

4.2 Disk interface

The disk controller consists of two micromachine tasks, four R-registers, about 150 microinstructions, and 55 MSI TTL ICs (Figure 11). The hardware is modest because it takes advantage of the computational power available in the micromachine. The hardware does only what the micromachine cannot do, either because of performance limitations or because remote sensing or control is involved: cable driving and receiving, data buffering, data serialization and de-serialization, data encoding, sync pattern detection, and micromachine communication. With the particular disk drive used on the Alto (Diablo Model 31), the disk controller is responsible for encoding data into a self-clocking Manchester code during a write operation, but during a read operation the disk drive itself performs data-clock separation.

Various applications eventually led us to interface a much higher performance disk (CalComp Trident) as an option. The differences between the two disk controllers are almost entirely in areas where the micromachine has sufficient performance to handle some function for the slower disk, but not for the faster one. For example, although the Alto has sufficient main memory bandwidth to handle the Trident (9 Mbits/sec vs. 1.7 Mbits/sec for the Diablo), task wakeup latency (the time from when a wakeup is requested to when the task gets control of the micromachine) can be up to 2 μ s, so multi-word buffering hardware is required in the faster controller.

4.2.1 Disk sector task

One micromachine task, called the sector task, is invoked whenever a sector notch on the rotating disk pack passes a reference location on the disk drive. There are 12 such notches around the disk, and one of them passes the reference location every 3 ms. The sector task can run at low priority because its needs for micromachine computation (about 12 μ s) can be satisfied at any time in a 100 μ s interval. When the sector task is invoked, it records the final status of the just-completed transfer operation (if there was one) in that operation's disk command block, records any requested interrupts in NIW, and checks to see if another command block requires processing. If there is no work to do, the sector task goes to sleep. This permits lower-priority tasks to run until another sector notch is encountered.

If there is new work, the sector task decides whether the disk access machinery is positioned at the correct cylinder and sector. If the cylinder is incorrect, a seek operation is initiated, using the controller hardware. If both sector and cylinder positions are correct, the data transfer is enabled by leaving the necessary state information in R-registers, and commanding the controller to generate disk data task wakeup requests. Finally, the sector task sleeps.

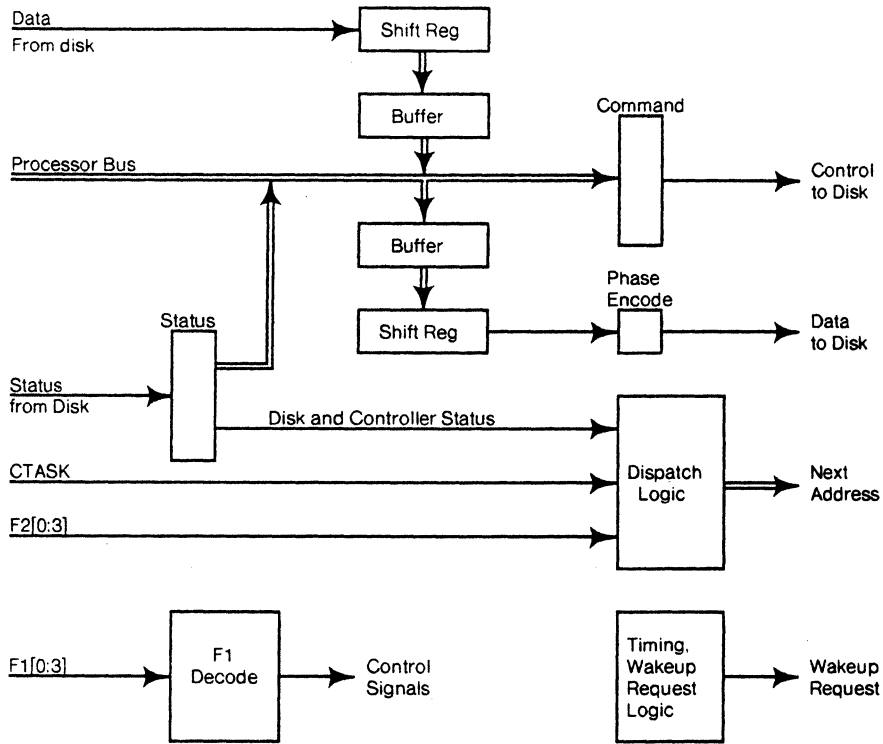

Control Block Format:

0	Pointer to next command block or zero if last
1	Ending status
2	Seal Command
3	Header Block memory address
4	Label block memory address
5	Data block memory address
6	No error interrupt bits
7	Error interrupt bits
8	unused
9	Disk address

4 R registers
 144 Microinstructions
 55 MSI TTL ICs

Figure 11. The disk controller.

4.2.2 Disk data task

The other task, called the disk data task, is invoked at a very high priority during reading (or writing) whenever the one-word data buffer in the controller needs emptying (or filling, respectively). This task is awakened about every 10 μ s, and transfers a single word in at most 1.7 μ s (unlike the display task, which transfers two words per wakeup in 1 μ s). Thus during disk transfers up to 20% of the micromachine's time is devoted to servicing the disk controller.

The disk data task is expected to read, check, or write each of three records in a sector: the header, the label, and the data. Each record consists of a preamble area written as all 0 bits, a synchronization pattern consisting of a single 1 bit, a number of information words, and a checksum word. The preamble and synchronization bits allow a tolerance for mechanical and electrical misalignment between writing and reading.

In a typical operation the data task might check the header and label records of a sector, and then write its data record. To read or check a record, the Alto waits until the disk head is over the preamble to that record, then reads until the sync pattern is recognized, then gets words from the disk and writes them into memory or compares them with words fetched from main memory, and finally compares the computed checksum against the one read from the disk. To write a record, it must write a certain amount of preamble, then a sync pattern, then the data fetched from main memory, and finally the computed checksum.

A small piece of actual microcode for the disk data task will make the preceding description concrete. In the microassembly language below, all the clauses between a pair of semicolons (; xxx \leftarrow yyy, zzz, ... ;) assemble into one microinstruction (see Figure 5). For example, in the first line,

```

;
InPreambleWait:
  L  $\leftarrow$  MinusPreambleRemaining+1, Block;

```

MinusPreambleRemaining is an R register (say, 16), so RSEL = MinusPreambleRemaining (16), ALUF = BUS+1 (5), BS = \leftarrow R (0), F1 = BLOCK [task specific] (3), F2 = NULL (0), LL = Yes (1), LT = No (0), and the NEXT field is assigned by the microassembler to point to the next microinstruction in sequence. The label InPreambleWait is defined to be the microinstruction address chosen for this microinstruction by the microassembler.

One further general point is that conditional jumps and dispatches are implemented by ORing a computed value (usually just 0 or 1, but not always) with the NEXT address being fetched as part of the next microinstruction. Conditional clauses are identified by a trailing ?. For example,

```

...,L<0?,...;
...,GoTo[0:PreambleDone, 1:InPreambleWait],...;

```

The L<0? clause in the first microinstruction will cause a 1 to be ORED with the NEXT field of the next microinstruction, if and only if the previous value of the L register is negative. The second microinstruction includes a NEXT field pointing to PreambleDone, and in addition it tells the

assembler to locate `PreambleDone` at an even address and `InPreambleWait` at the next successive odd address, so that `PreambleDone OR 1 = InPreambleWait`.

The microcode fragment given below uses several functions to communicate with the hardware interface. All of them are task-specific.

`Block (F1)` tells the controller hardware that the microcode task has run, and the wakeup request should be removed.

`DiskBufferWord← (F1)` loads the one-word output buffer in the disk controller hardware from the bus.

`←DataBufferWord (BS)` puts the contents of the one-word input buffer in the disk controller onto the bus.

`DiskCommandRegister← (F1)` loads the command register in the controller from the bus. The bits in that register then fan out to control several independent conditions in the controller hardware. One bit (`UseReadClock`) determines whether the controller bit clock is being generated from a crystal oscillator in the controller, or whether it is inferred from the data being read from the disk. Another bit (`WaitForSyncPattern`) determines whether the controller should suspend wakeup requests until the arrival of the sync pattern from the disk.

`ReadWriteOrCheck? (F2)` causes a 2-bit dispatch based on whether the record is to be read, written, or checked (compared with memory data). The two bits have earlier been placed by the microcode into a special register in the disk controller.

The code begins with a description of the R registers used:

The code uses four R registers, although for clarity five names are used:

`MinusPreambleRemaining`: a negative count of the number of words of preamble remaining.

`RecordWordCount`: the number of words in the record being read or written (e.g., the data record is 256 words long).

`BufferBottom`: the address of the first word in main memory of the buffer for this record.

`OneBeyondNextBufferWord`: a pointer into the main memory buffer where the next word should be placed. The pointer is always "one beyond" where the actual store will be done.

`Checksum`: a register to accumulate the exclusive OR of all data words read or written in the record.

As we join the story, the data task has begun "spacing" into a disk record in preparation for reading, writing, or checking it. If reading or checking, this means marking time until good data is known to be under the read head. If writing, this means writing preamble.

In this loop the microcode counts through the preamble, one count per data task wakeup. Although no data is being transferred, the disk controller is waking up the data task each time the 16-bit buffer is full, so that it can count preamble bits. Between wakeups, the data task's micro-program counter rests pointing at either `InPreambleWait` or `PreambleDone`.

```

;
InPreambleWait:
  L ← MinusPreambleRemaining+1, Block;
  MinusPreambleRemaining ← L, L<0?, Task;
  DiskBufferWord ← PreambleConstant,
    GoTo[0: PreambleDone, 1: InPreambleWait]; Send more preamble if writing.

```

Now the preamble waiting is over. If reading, this means that the head is known to be over a good preamble area before the sync pattern. If writing, this means we should now write a sync pattern.

PreambleDone:

```
T ← RecordWordCount;
L ← BufferBottom+T, ReadWriteOrCheck?;
OneBeyondNextBufferWord ← L, Block, Set up pointer into buffer.
  GoTo[0:SetupRead, 1:SetupWrite, 2:SetupCheck];
```

SetupCheck:

```
  Adjust by 1 to make transfer loop exit test more efficient.
L ← BufferBottom-1;
BufferBottom ← L;
```

SetupRead:

```
DiskCommandRegister ← UseReadClockAndWaitForSyncPattern,
  GoTo[SetupChecksum];
```

SetupWrite:

```
DataBufferWord ← SyncPatternConstant;
```

SetupChecksum:

```
L ← StartingChecksumConstant, Task; Initialize Checksum register.
```

ModifyChecksum:

```
Checksum ← L;
```

The data task's micro program counter rests here between transferring words. If we are reading, and if this is the first word of the record, then the data task will wait here until a word has been read following the deserializer's recognition of a sync pattern. Note that the transfer loop transfers data from high to low addresses; this simplifies the exit test.

TransferLoop:

```
MAR ← L ← T ← OneBeyondNextBufferWord-1;
  Start main memory interface by supplying address to MAR.
OneBeyondNextBufferWord ← L, ReadWriteOrCheck?;
L ← BufferBottom-T, Compute number of words remaining to transfer.
  GoTo[0:ReadLoop, 1:WriteLoop, 2:CheckLoop]; Dispatch.
```

ReadLoop:

```
T ← Checksum, Block, L=0?; Check L: Enough words transferred?
L ← (MD ← DataBufferWord) XOR T, Task,
  GoTo[0:ModifyChecksum, 1:TransferFinished];
  Move data word from disk controller to memory, modify checksum.
```

WriteLoop:

```
T ← Checksum, Block; Recall L contains number of words to transfer.
L ← (DataBufferWord ← MD) XOR T, L=0?;
  Move data word from memory to disk controller, modify checksum.
  Check L: enough words transferred?
Task, GoTo[0:ModifyChecksum, 1:TransferFinished];
```

TransferFinished:

```
Checksum ← L;
```

The task's program counter rests here after sending the last data word to the controller, or reading the last data word from the controller. Now we must either send the computed checksum to the controller or compare the computed checksum with that read from the controller.

```
T ← DataBufferWord ← Checksum, ReadWriteOrCheck?;
```

Only writes into outgoing buffer word.

```
L ← DataBufferWord-T, Block,
```

GoTo[0:CheckChecksum, 1:FinishRecord, 2:CheckChecksum];

This uses the incoming buffer word.

Now if we were reading or checking, we test for correct checksum by checking whether L is 0. etc.

In the main reading loop, all but one of the microinstructions are executed concurrently with the main memory transfer (i.e., between MAR+ and MD+, which are as close together as they can be). This is usually true as well for other high-bandwidth controller microcode loops in the machine. Thus the main speed bottleneck in the Alto is shared access to a single memory interface. The additional degradation resulting from also sharing a single processor is minimal because so much processing is overlapped with memory references.

ReadWriteOrCheck? is a good example of trading off controller hardware against shared processor time, register space, and microcode space. Obviously the same effect could have been obtained by dispatching on the value in an R register in the micromachine, or by having completely separate micromachine routines for reading, writing, and checking. Usually the decision was made to minimize controller hardware. But in this case by introducing a small amount of extra hardware (about two ICs) in the controller, one R-register or about 30 microinstructions were saved. It was economical in 1973, but might not be today.

5. Communication

A personal computer provides substantial, predictable service to a single user. Much of the service he wants, however, cannot be provided by his machine alone, either because sharing is essential to the service or because of cost. Communication with other computers and other users is therefore needed. The communication system expands the service available to an individual, by allowing several users to share resources.

Such sharing is advantageous for two reasons. First, it allows several users to access the same data. For example, a person who composes a memorandum using text-editing facilities contained entirely in his Alto, may wish to distribute copies to several other people. He transmits the data representing the memorandum to the Altos of the recipients; each of the recipients can then read it on his Alto display. This use of communication is analogous to the use of the telephone or U.S. mail.

Communication can also be used to share resources for economic reasons. Although it is too costly to provide a hard-copy raster-scan printer for each Alto, a group of users may share a printer, transmitting to the printer the data and control information necessary to print a document. Sharing is also economical for high-capacity file storage or for special-purpose processors too expensive to replicate for each person.

At the time the Alto was designed, several computer communication networks such as the ARPA network [Kahn] had demonstrated the value of packet-switched networks for sharing resources and providing personal communication among research collaborators. A design suited for personal computers, however, has objectives rather different from those of a remote computer network such as the ARPA net:

The transmission *speed* should be high enough that most users will not notice the presence of the network. If network bandwidth approximately matches local disk bandwidth, the user may not know or care whether a file is retrieved from a local disk or from a remote disk.

The *size* of a network linking personal computers must not be limited. It is not unreasonable to imagine networks linking thousands of personal computers. At the same time, just two or three computers can constitute a reasonable network.

The *reliability* of the network is extremely important when essential services such as printing depend on communication. If a user's personal computer malfunctions, he can take his disk cartridge to another one, but a network malfunction severs his access to essential services. In addition, many users are inconvenienced when the network fails, but only one when a machine fails.

Personal computers tend to be near to each other and to the services they need, thus permitting a *local* network transmission technique for clusters of machines.

A design for a communication system must anticipate the need for *standard communication protocols* in addition to standards for the physical transmission media. The protocols control the flow, routing, and interpretation of data in the network. Just as the design of the Alto disk controller addresses the needs of a file system, so must the design of a network address the needs of communications protocols. However, the Alto was designed at a time when experience with protocols was limited: many lessons had been learned from the ARPA protocols, but newer designs such as Pup [Boggs *et al*] and TCP [Cerf-Kahn] had yet to emerge. The Alto therefore provides a general packet transport system, which has been used for a number of protocol experiments and evolutionary designs.

5.1 *The Ethernet local network*

The Ethernet communication system [Metcalfe-Boggs] is the principal means of communication between an Alto and other computers. An Ethernet is a broadcast, packet-switched, digital network that can connect up to 256 computers, separated by as much as a kilometer, with a 3 Mbit/sec channel. Control of the Ether is distributed among the communicating computers to eliminate the reliability problems of an active central controller, and to reduce the fixed costs which can make small centralized networks uneconomical.

A standard Alto includes an Ethernet controller and transceiver. As soon as there are two Altos within a kilometer of each other, connecting the transceivers together with a coaxial cable establishes an Ethernet. Additional Altos and other computers can be connected simply by tapping into the cable as it passes by, above a false ceiling or beneath a raised floor. Connections can be made and power turned on and off without disturbing network communication.

An Ethernet is an efficient low-level packet transport mechanism which gives its best efforts to delivering packets, but it is not error free. Even when transmitted without an error detected by the sender, a packet may not reach its destination without error; thus, packets are delivered only with high probability. A hierarchy of layered communication protocols is used to achieve reliable transmission on the Ethernet, by requiring receiving processes to acknowledge receipt of correct packets and sending processes to retransmit packets whose correct receipt is not acknowledged.

5.2 *The internetwork*

Although the physical size and addressing of the Ethernet are limited, many local networks may be connected together into an *internetwork*. The internetwork is implemented by building *gateway* computers (usually Altos) that connect two or more networks, often using long-haul digital communication to connect with gateways on distant local networks. The gateway is responsible for routing packets in the internetwork: it receives a packet from a local network, interprets a destination address in the packet, and then transmits the packet into another network which will get it closer to its ultimate destination. Sometimes packets are forwarded through several gateways

before they arrive at the proper local network. As of summer 1979, the Xerox internet provides service to several hundred computers on 25 networks interconnected by 20 gateways.

5.3 Implementation

The Alto Ethernet controller (Figure 12) contains about 75 MSI TTL ICs—it is slightly larger than the disk and display controllers. The transceiver, on the other hand, is much smaller and less expensive than either the disk drive or the display monitor. The controller hardware consists of the following functions: phase decoder, receiver shift register, FIFO buffer and synchronizing register, transmitter shift register, phase encoder, and micromachine interface. The FIFO buffer is shared by the transmitter and receiver, so the interface is half-duplex: it can either be transmitting or receiving but not both simultaneously. This is not a severe limitation, since the Ether itself is half-duplex. It does make hardware checkout more difficult, however, because the controller cannot be looped back on itself; also, the software must make a special check for packets that it sends to itself. Up to three Ethernet interfaces can be attached to an Alto. Unfortunately the tasks cannot share a single copy of the microcode, since the micromachine cannot make indexed R-register references.

The microcode uses one medium-priority task, two R-registers, and about 100 microinstructions. The task consumes 16% of the machine in the data transfer loops, since it runs for five cycles (one memory reference) every 5.44 μ s (one Ethernet word time), doing all of its bookkeeping while waiting for the memory. To reject a packet the address filter requires 13 cycles (2.21 μ s), which consumes as much as 20% of the machine in the improbable case of minimum length (2 word) back-to-back packets. The rest of the microcode is executed once per packet accepted or transmitted, and so consumes a negligible number of cycles.

The Ethernet task communicates with a program much as the disk and display tasks do. The program builds a command block describing the operation to be done. When the Ethernet task wakes up, it carries out the operation, and then posts status in the command block and causes an interrupt by ORing a word from the command block into NIW. The disk and display have periodically occurring events (sector notches and scan line retrace) which cause their tasks to wake up and check for commands from the software, but there is no such periodic event for an Ethernet. Instead, there is an S-group instruction which the program executes to set a flip flop in the Ethernet hardware; this flip flop wakes up the Ethernet task to act on the command block. Disk and display commands complete after a finite time, but an Ethernet receiver can be started and not receive a packet for days. Hence programs always use interrupts to recognize completion of an operation, rather than busy-waiting as many disk drivers do. Finally, Ethernet command blocks are not chained, partly because of a shortage of microcode space in the early implementations, and partly because it was not then clear how to make use of chaining.

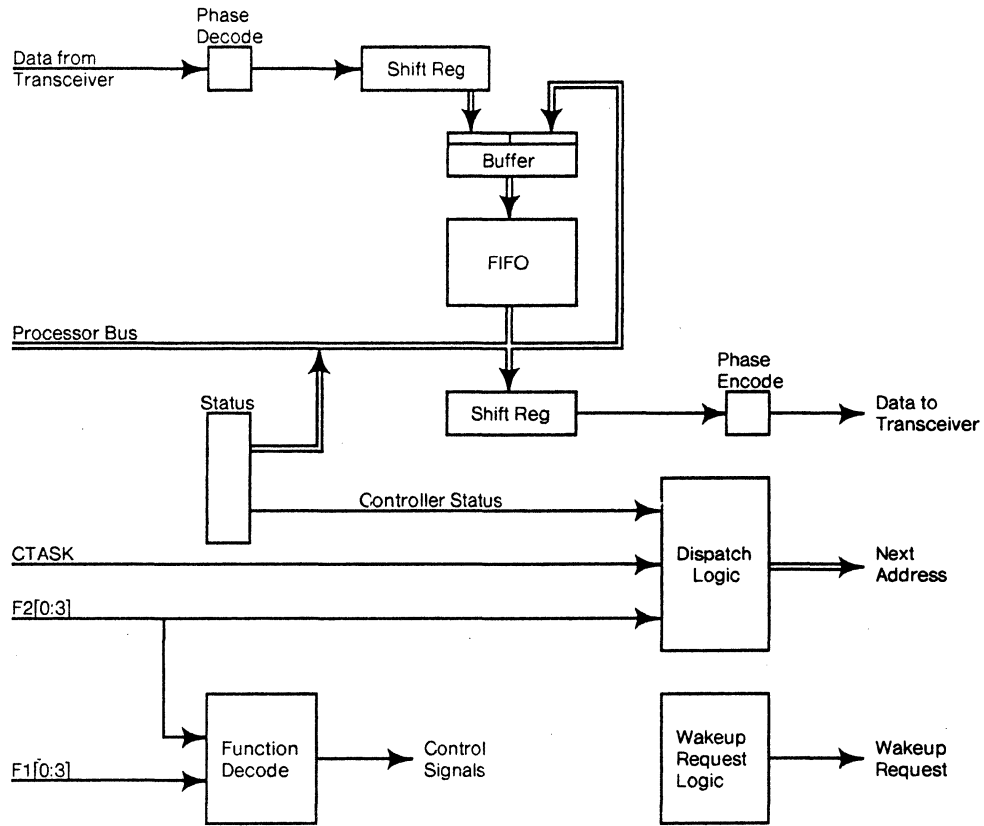

Control Block Format:

0	Microcode Status	Hardware Status
1	Interrupt bits	
2	Buffer words remaining	
3	Load	
4	Input buffer size	
5	Input buffer memory address	
6	Output buffer size	
7	Output buffer memory address	
8	Unused	Host address

2 R registers
 95 Microinstructions
 75 MSI TTL ICs

Figure 12. The Ethernet controller.

Packet address filtering is done by the microcode. When the hardware has accumulated the first word of a packet, it wakes up the microcode to check the destination address byte. The microcode accepts the packet and copies it into memory if any of the following conditions is met:

- the destination address in the packet matches the *host address* field in the command block;
- the destination address is zero (in this case the packet is a *broadcast* packet, and is received by all machines);
- the host address is zero (in this case the machine is said to be *promiscuous*, and receives all packets).

Otherwise the microcode tells the hardware to ignore the rest of the current packet, and go to sleep until the beginning of the next packet. The address filter takes about 20 microinstructions; done in hardware it would take about 8 ICs.

The flexibility afforded by this filtering scheme has many applications. Any machine can substitute for another by using the other machine's address in the host address field. Promiscuity is invaluable for debugging protocols, since a machine can peek at all of the packets flowing between two others. It is also easy to study the performance of the net by monitoring all the traffic. Broadcasts are used to locate resources and to distribute globally useful information. A less desirable consequence is that the Ethernet itself provides no security; applications which need secure communication must use encryption.

The choice of an eight bit address has proved to be unfortunate, since it means that a machine cannot have a unique hard-wired serial number which is normally used as its host address. Instead, each Alto has a station address specified by jumpers on the backplane, which is unique only among the machines on the particular Ethernets it happens to be on.

Two or more Ethernet transmitters *collide* when they simultaneously decide that the Ether is free and begin transmitting. When a transmitter detects collision, it aborts transmission and waits a random time interval before trying again, so as not to collide repeatedly. As the load on the net increases, a transmitter retries less vigorously, by doubling the mean of its random interval each time it participates in a collision. This *exponential backoff* algorithm is done by the microcode and a small amount of hardware. The software zeroes the LOAD location in the Ethernet command block each time it issues an output command, and the microcode shifts a one bit into it each time a collision happens. The microcode generates a random retransmission interval by masking the LOAD location with the real time clock R-register maintained by the timed task, and then waiting for that interval by telling the hardware to wake it up each time the timed task wakes up, and decrementing the interval register at each wakeup. When the register goes to zero, the microcode again tries to transmit. After 16 consecutive collisions the LOAD location overflows, and the microcode gives up and posts a failure code in the command block. This algorithm takes about 20 microinstructions; done in hardware it would require about 10 ICs.

6. A controller for a raster-scanned printer

The Alto is predominantly a versatile I/O controller: the design emphasizes the needs of high-bandwidth I/O for personal computing, and relegates instruction interpretation to secondary importance. One of the objectives of the design is to provide a convenient framework in which to build experimental or special-purpose I/O controllers, in addition to those for the standard display, keyboard, mouse, disk, and Ethernet. This section illustrates how the resources of the Alto are harnessed to a complex task: an interface to a high-speed raster-scanned page printer. The design shows how the page-generation algorithm is first analyzed, and then divided into parts that are implemented in software, microcode, and hardware.

The objectives of a printer are very similar to those of the Alto display: several thousand characters may appear in arbitrary sizes, rotations, font styles, and positions on the page; text may be proportionally spaced; characters may overlap one another (e.g., overstrikes); non-text imagery such as lines and curves may appear. Printing quality generally exceeds that of a display by using higher resolution—a typical device might print in one second an 8.5 by 11 inch page defined with 350 dots/inch (roughly 4000 horizontal scan lines of 3000 dots each).

These observations suggest that the same techniques used to generate a digital video signal for the Alto display be used to drive a printer. The modest average data rate of 12 Mbits/sec means that an image of the page could be buffered in Alto memory and read out to generate video, using the same sort of controller as the Alto display. The image of the printed page can be created the same way as that for a display: using a *character table* that gives the x and y position and character code for each character that appears in the image, and a *font table* that defines a rectangular bitmap pattern for each character, BitBlit is used to OR each character's pattern into the bitmap buffer at the proper coordinate position. Unfortunately, this simple approach fails for two reasons: the Alto does not have enough memory to buffer a full page image (12 million bits), and the processor cannot execute BitBlit fast enough to generate a bitmap for a moderately complex page in one second. These two problems force changes in the image-generation algorithm. After describing the new algorithm, we sketch its Alto implementation.

Because buffering the entire page is impractical, an *incremental algorithm* must be used to generate portions of the image in sequence, using a smaller buffer. The image is divided into *bands* of 16 scan lines each, and the entire page image is generated by creating the image for each band in turn. This scheme requires two buffers, each capable of holding the bitmap for a single band: while one buffer is being converted into a video signal and sent to the printer, the image of the next band is being prepared in the other buffer.

The incremental approach requires modifications to the image-generation algorithm described for a full-page buffer. The problem is to identify those characters that lie wholly or partly in the band being generated. Although the entire character table can be scanned to compute, for each entry, whether the character lies in the band, it is more efficient to sort the table by the band number in which the character begins (i.e., by y coordinate of the topmost scan line). The sorted

table allows easy identification of "new characters," those that start within the band being generated.

Breaking the page image into bands inevitably causes some characters to span two or more bands, either because they are more than 16 scan lines high, or because their image on the page happens to cross a band boundary. For these characters, the image-generation process is not completed when a band is generated; instead, a portion of the character is *left over* and must be continued in the succeeding band (Figure 13). The image-generation algorithm records left-over characters in a list that contains sufficient information to continue image generation (BitBlt) in the next band. The companion data structures for new and left-over characters are characteristic of many incremental image-generation algorithms, such as those for solid polygons and hidden-surface images [Newman-Sproull]. The algorithm to generate the image of a band is:

- 1) Clear the band buffer to zero.
- 2) For each character in the character table for this band:
 - 2a) Use the character code extracted from the character table to enter the font table and find a character bitmap, together with a width and height.
 - 2b) OR into the band buffer the image of the character, at the specified position.
 - 2c) If the character's image does not terminate in this band, save a left-over entry, specifying the *x* position of the character, its width, its height (now reduced), and a pointer to the beginning of the next scan line of character bitmap information in the font table.
- 3) For each character in the left-over table formed when generating the previous band:
 - 3b) Same as step 2b.
 - 3c) Same as step 2c.
- 4) The image in the band buffer is now ready to be converted into a video signal and sent to the printer.

The algorithm was analyzed carefully to design an implementation for the Alto. Table 1 gives several properties required of the memories used in the algorithm, obtained by software simulations of the printing of typical pages. These simulations lead to a number of design decisions for the algorithm and controller. Consider the size of a band: 16 scan lines. The greater the number of scan lines in a band, the larger the band buffers, and hence the expense. The smaller the number of scan lines, the more frequently the left-over tables must be read and written while generating a page. The table shows that a band size of 16 scan lines yields both modest left-over bandwidths and inexpensive band buffers. It also shows that the memories required divide into two classes: small and fast (band buffers) and large but slow (font, character and left-over tables). This division leads to an implementation strategy for the Alto: the main memory will hold the font, character, and left-over tables, and the controller will hold the band buffers, together with some image-generation aids. Such a division is feasible only because the Alto micromachine can intimately control the image-generation hardware, using character parameters and pattern information read from main memory.

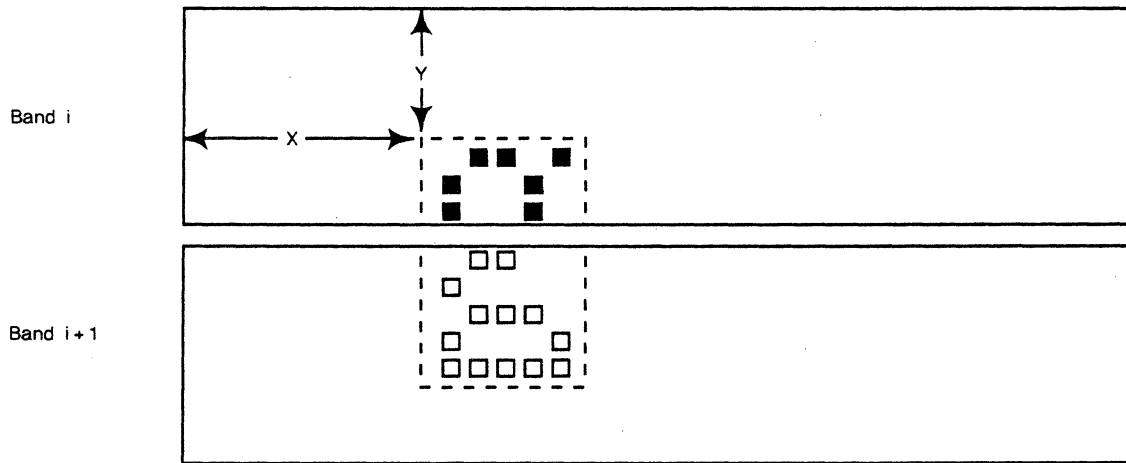
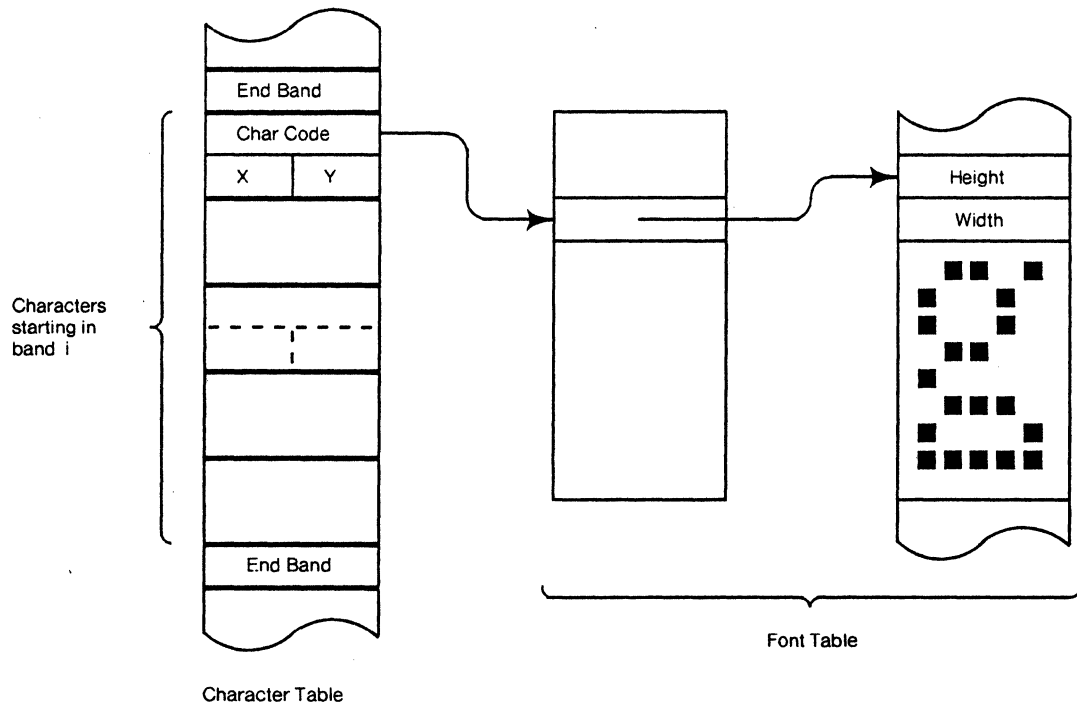

Figure 13. Schematic diagram of the image-generation process for printing a page. The band buffers show a character that does not completely fit in band *i*. It has a "left over" part extending into the next band.

Table 1

	Size (bits*10 ³)	Bandwidth (bits*10 ⁶ /page)
Band buffers	30	
Clear buffer		12.3
Generate image		6+
Output video		12.3
Font table	368+	2.4+
Character table	80+	.08+
Left-over list	6.4+	.5+

Numbers ending in "+" increase roughly linearly with page complexity.

6.1 Implementation

The organization of the printer controller is shown in Figure 14. It is logically divided into two parts that operate concurrently, the *video generator* and the *image generator*. The video generator reads data from one of the two band buffers, converts it into a video signal, and transmits the signal to the printer. As each 16-bit word is read from the buffer, zeroes are written back to clear the buffer for subsequent image-generation. When the video generator has emptied a buffer, it switches buffers and begins emptying the other one.

The image generator portion of the controller composes the image in the buffer that is not being sent to the printer, under control of microcode in the *printing task*. The micromachine sets several parameter registers that describe the dimensions and position of a character to be added to the band buffer (*width, height, x, and y*). Then it enters a tight loop, reading the character's bitmap pattern from the font table, and passing two 16-bit words to the controller every microsecond. This pattern passes through a FIFO and is shifted to align it with the word boundaries of the band buffer. After masking to account for the ends of a character, these 16 values are used to enable writing new data values into selected bits of a particular band buffer word. An "ink" memory provides the data to be written at these positions. Thus the character pattern, shifter and mask determine *where* a character appears in the band, while the ink memory determines the *video data* values, and thus allows characters to appear to have texture or halftone patterns. When the interface signals to the processor that it is finished processing the current character, the microcode reads the controller status, including the height register, to determine whether the character was completed, or whether a left-over entry must be made, and records the left-over entry in Alto memory if necessary. The microcode repeats this process for all the characters that appear in the band. When the image for the band is completed, the printing task sleeps until the video generator switches buffers, indicating that the task must begin generating the image of the next band.

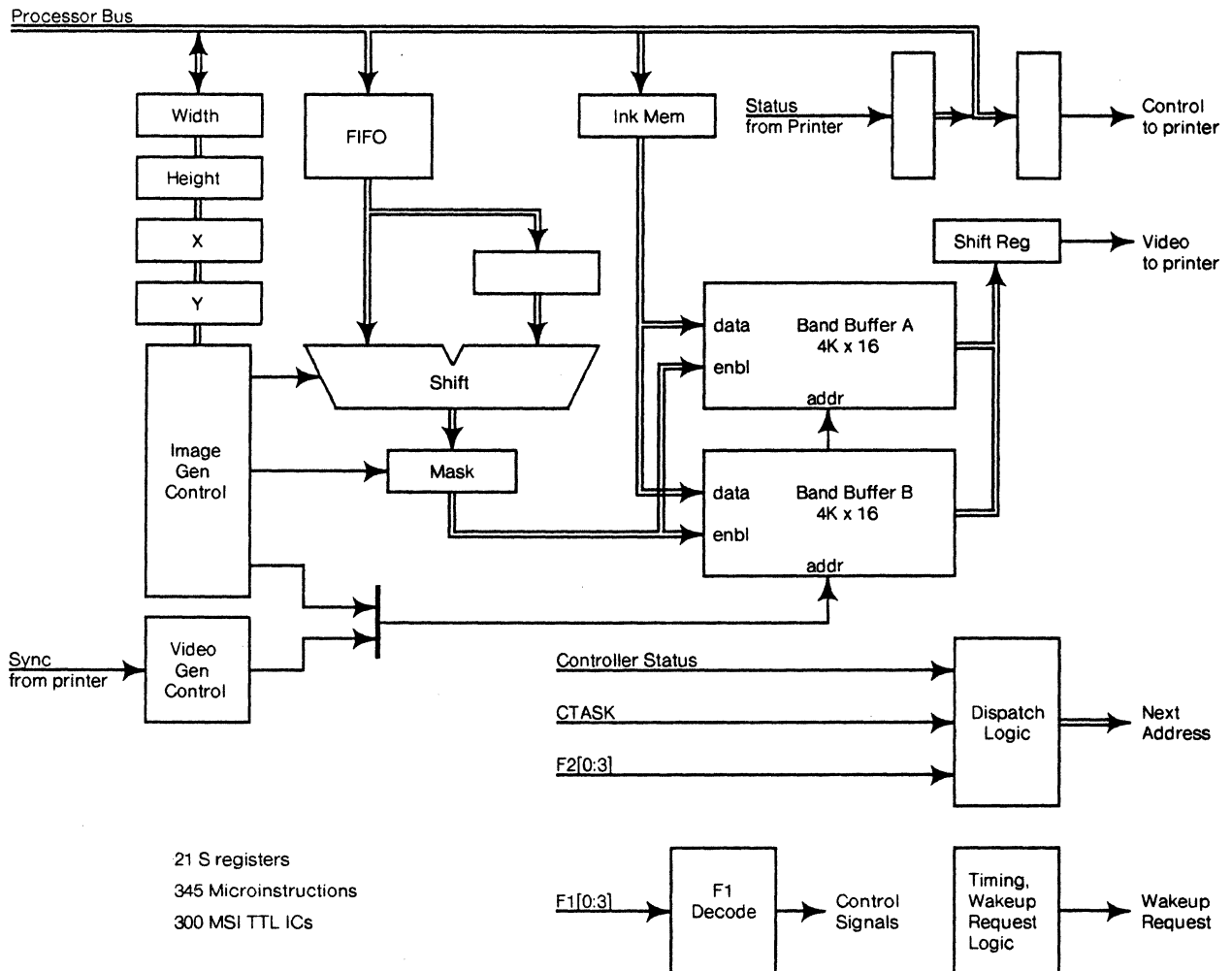

Figure 14. The printer controller.

The design of the printer controller is extremely economical, because it takes maximum advantage of the facilities already available in the standard Alto: substantial memory and a versatile micromachine. This approach retains the flexibility to change easily the sizes, formats, and contents of important structures: the font and character tables. The special hardware helps implement a general mechanism for composing page images (BitBlit), a mechanism that places no restrictions on the size, position, or content of characters, nor on the number of different character shapes that can appear on a page. Indeed, the controller will generate arbitrary video patterns, including lines, curves, and halftones. The performance of the system is limited by two constraints: (1) the font and character tables must not exceed the size of Alto main memory; and (2) the time available to generate a band dictates the number of micromachine cycles available to read character patterns from memory and pass them to the controller.

Each of several dozen printers in the Xerox research environment is driven by a printer controller, plugged into a standard Alto. Although the page-printing task is complex, the special hardware is not large (about 300 ICs) because of extensive use of microcode and memory resources in the standard Alto. The design illustrates how a page-generation algorithm was analyzed and then implemented using appropriate facilities: macroinstruction programs for y sorting, microcode for left-over table management and font table references, and special hardware for the "inner loops" of image and video generation.

7. Applications

A successful personal computing environment depends not only on economical hardware and devices for communicating with humans, but also on software constructed to meet personal computing needs. This section surveys the major software systems that have been built, and discusses the impact of the local network on the Alto computing environment.

7.1 Programming environments

Two kinds of programming environments have developed on the Alto: conventional compiler-based systems, and fully interactive environments. The first conventional environment to be constructed is implemented almost exclusively in the BCPL programming language, and includes common tools: a compiler, an assembler, a linker, a debugger, an "open" operating system [Lampson-Sproull], a command processor, file-manipulation utilities, etc. Subsequently, the Mesa programming language was designed and implemented on the Alto [Geschke *et al*] [Mitchell *et al*]. Both of these environments have been used extensively to build applications.

Interactive programming environments emerged to take advantage of the personal nature of the Alto. The Smalltalk environment turned the Alto into an "interim Dynabook," a prototype for a personal dynamic medium that emphasizes visual and audio communication [Kay-Goldberg] [Kay77] [Kay78] [Ingalls]. Smalltalk has been used to interact with documents containing text and graphics, to build visual animations [Baecker], to synthesize music, and to build a variety of simulations of personal interest.

An implementation of Interlisp [Teitelman78] explored the problem of providing a large interactive environment on the Alto [Deutsch]. Although the Alto micromachine was successfully adapted to interpret byte-coded Interlisp instructions at reasonably high speeds, the small main memory of most Altos at the time (64k) proved to be a crippling performance limitation.

The various programming environments used on the Alto coexist gracefully by sharing only files stored on the local disk, and network protocols for communication among computers. No other facilities of the Alto are standardized. This policy allows each environment and each application to exploit the hardware in novel ways; for example, it fosters different strategies for using the display and interacting with the user. It also allows a language or application to use special-purpose microcode to interpret instructions or perform application-specific calculations. The policy has a few drawbacks: failure to standardize the use of the display, for example, makes it essentially impossible for one Alto to be used as a remote terminal to another one.

7.2 Personal applications

Some applications use the Alto as a stand-alone computer, usually making extensive use of the display, mouse and keyboard for interaction. The most commonly used applications of the Alto

today are the various programs developed for document production: a text editor that supports a wide range of formatting styles and text fonts, and a set of "illustrators" to prepare diagrams using geometrical figures such as lines, circles, and curves, or raster images obtained by scanning existing documents or by free-hand drawing. Many of the display techniques used are described in [Newman-Sproull]; camera-ready copy for that book was produced with Alto document-production software.

Some uses of the Alto support research in computer science within Xerox. The best example is a design automation system used to aid designers of digital hardware. Logic drawings are prepared with an illustrator, and are then analyzed by a program to determine what integrated circuits are pictured in the diagram and how they are connected. Other software then checks loading rules, makes wire lists, and drives semi-automatic wiring equipment. The Alto also serves as a console computer to simplify debugging or diagnosis of experimental hardware. An umbilical cord connects the Alto to the hardware so that it can load registers and memories, issue control commands such as "single step," and read back important internal state. An Alto program presents this information on the display, accompanied by symbolic names of the registers or signals in the experimental hardware. The display also presents menus of operations, such as "step," that are invoked by pointing with the mouse and cursor. In this way, the Alto is used to provide a comfortable user interface for an engineer, technician or system programmer working on the hardware.

7.3 *Communication in applications*

No Alto users depend only on the resources available within a single Alto; all use communication to extend these services. Even the user of document-production application requires communication to obtain hardcopy output at a shared printer or to distribute a document file to other users. Alto applications and users depend on a wide variety of services implemented on *server machines* throughout the network:

- *Printing.* An application program running in any Alto may transmit to the *printing server* a description of a document to be printed. The printing server is an Alto that queues requests, and later prints the files using the raster printer controller described in Section 6.
- *File storage.* File services are provided both to allow sharing of files among users and to escape the limitations of the local storage available on the standard Alto. The service machines have one or more high-performance disks attached, and offer several different styles of file access. Some provide a "page level" access [Swinehart *et al*], some a "file transfer" access patterned after the ARPA network file transfer facilities [Crocker *et al*], and some a "transaction access" suitable for implementing a file service that is distributed over several machines [Lampson-Sturgis] [Israel *et al*].
- *Mailboxes.* A popular application of the Alto is an electronic mail service. The personal machine is used to prepare messages for transmission to other Alto users, and to display and retain on the disk messages that have been received. A network mailbox service is

provided to hold messages for a user until he wishes to receive them with the mail program. The mailbox service is often implemented within the same computer that provides network file storage [Levin-Schroeder].

- *Timesharing.* The Alto can be used as a terminal on the MAXC timesharing system [Fiala]. For simple applications, the Alto simulates a conventional video character display. More ambitious applications use a "display protocol" to format text and graphics carefully on the screen [Sproull]. DLISP, which provides display-oriented access to the Interlisp programming environment, is the primary user of the display protocol [Teitelman77].

- *Time of day.* A simple but necessary service is to inform Altos of the correct time. A time server is conveniently located in the same computer as a communication gateway.

- *Error logging.* This service records a log of error information sent to it, and is usually operated by hardware and software maintenance groups. Altos that are not in use run a diagnostic program that periodically sends error summaries to the logger. The maintenance organization examines the log to schedule service calls.

- *Bootstrap.* Alto microcode allows the computer to be bootstrap-loaded from either the local disk or the Ethernet. An Ethernet bootstrap service accepts a request for an Alto program, reads it from a local disk, and sends it over the network to the computer making the request. This service was first used to bootstrap the Scavenger program which repairs a damaged disk file structure. Many programs are now distributed in this way, reducing the demands on local disk storage. The ability to bootstrap diagnostic programs over the Ethernet is especially useful to the maintenance staff.

The services outlined above are implemented on various server machines spread throughout the internetwork. Servers can be added or removed straightforwardly as needs grow or shrink. All application programs access the services using standardized protocols, which in effect define the services that are offered. Standardization is necessary to allow sharing; applications that share a file must obey the protocol standards of the service used to store the file. Thus the protocols constitute a standardized interface, analogous to the file system on the disk, which is observed by all programs in the environment [Boggs *et al*].

In addition to standard services, individual applications use the network in special ways. For example, the debugger may communicate with an identical debugger running elsewhere in the network, essentially passing the user's commands to the remote machine and returning information to be displayed. Thus a programmer in California can examine and fix a bug on a machine in New York. The Ethernet is used as a performance-analysis tool: the program to be analyzed transmits packets that summarize system status or that record the occurrence of a particular event. An analysis program running elsewhere in the network records and displays the information [McDaniel]. The network is also used to couple programs together so that two people can cooperatively edit and illustrate documents in real time, sending digitized voice as well as keystrokes and mouse movements through the network.

8. Conclusions

As an experiment in personal computing, the Alto has been very successful. The number of Altos in use exceeds the original expectations of its designers by more than an order of magnitude.

The Alto has led to an entirely new kind of computing environment, because it puts computing power near the user, and makes it possible for him to do most of his work without relying on a centralized facility. The Alto environment provides a high bandwidth, comfortable user interface, is extremely reliable because of its distributed nature, and provides performance that scales linearly with cost. One of the Alto's most attractive features is that it does not run faster at night [Morris].

A few aspects of the Alto design did not work out well. The limitations on the size of the address space and on the amount of real memory have been serious. Although some programming systems have been able to take advantage of the extended memory banks, not all Altos have this extension, and a great deal of time has been spent fitting standard software that must run on all machines into the limited space available. To a great extent, the memory size limitation is due to the fact that the system's life has been longer than planned.

The facilities of the micromachine are not well suited for emulating existing architectures with structured opcodes. Fortunately, the virtual machines for which new emulators have been built use simple instruction encodings that fit well with the micromachine's dispatch mechanism. The emulator for the Mesa machine interprets instructions just as fast as the emulator for BCPL, even though the latter has some hardware assistance for decoding, and the former does not.

The sharing of the micromachine among I/O activities and emulation has been extremely successful. The micromachine allows these activities to interact by sharing memory, and provides the high memory bandwidth necessary to support the high-speed I/O requirements of the personal computer. Today, hardware costs are low enough that it is possible to replicate the processor in every I/O controller, but if this is done without taking additional steps such as using cache memories to decouple the processors from the memory, or using more complex multi-ported memories, shared memory access will still limit the system's performance. Since both these alternatives add cost, while the multitasking is very inexpensive, we feel that this architecture is still viable today.

Some of the early decisions in the design of the Alto computing environment worked out very well. The arrangement by which all software is standardized at the level of disk files and network messages has made it possible to build a wide variety of cooperating software subsystems. The disk file system has proven to be extremely reliable, primarily due to the distributed redundancy. Although the hardware and software have both had bugs, the reliability *as perceived by users* has been exceptionally high, since files are almost never irretrievably lost.

The high bandwidth communication provided by the Ethernet has been more valuable than anticipated, since we underestimated the importance of servers. The network and network services have been the mainstays of the environment, and we feel that a facility with an order of magnitude lower bandwidth would have had a qualitatively different effect.

Acknowledgements

The concept and structure of the Alto are due primarily to Chuck Thacker, Ed McCreight, Butler Lampson, and Alan Kay. The hardware described in this paper was designed by the authors together with Roger Bates, Tat Lam, Bob Metcalfe, and Severo Ornstein. The working environment, network, software, and microcode that grew on the Alto are due to hard work and fine craftsmanship contributed by many members of the Computer Science Laboratory and System Science Laboratory of the Xerox Palo Alto Research Center.

References

[Baecker]

Baecker, R. M.: "A conversational extensible system for the animation of shaded images," *Computer Graphics*, 10(2):32-39, Summer 1976.

[Boggs *et al.*]

Boggs, D. R., J. F. Shoch, E. A. Taft, and R. M. Metcalfe: "Pup: an internetwork architecture," *IEEE Trans. Comm.*, COM-28(1), January 1980.

[Cerf-Kahn]

Cerf, V., and R. E. Kahn: "A protocol for packet network interconnection," *IEEE Trans. Comm.*, COM-22(5):637-648, May 1974.

[Crocker *et al.*]

Crocker, S. D., J. F. Heafner, R. M. Metcalfe, and J. B. Postel: "Function-oriented protocols for the ARPA computer network," *AFIPS Conf. Proc. (SJCC)*, 40:271-279, 1972.

[Deutsch]

Deutsch, P.: "Experience with a microprogrammed Interlisp system," to appear in *IEEE Trans. Computers*, C-28(10), October 1979.

[English *et al.*]

English, W. K., D. C. Englebart, and M. L. Berman: "Display-selection techniques for text manipulation," *IEEE Trans. Human Factors in Electronics*, HFE-8(1):5-15, March 1967.

[Fiala]

Fiala, E. R.: "The MAXC systems," *Computer*, 11(5):57-67, May 1978.

[Geschke *et al.*]

Geschke, C. M., J. H. Morris, Jr., and E. H. Satterthwaite: "Early experience with Mesa," *Comm. ACM*, 20(8):540-553, August 1977.

[Ingalls]

Ingalls, D. H. H.: "The Smalltalk-76 programming system: design and implementation," *Fifth ACM Symp. Prin. Prog. Lang.*, January 1978, pp. 9-16.

[Israel *et al.*]

Israel, J. E., J. G. Mitchell, and H. E. Sturgis: "Separating data from function in a distributed file system," *Proc. Second Int. Symp. Operating Syst.*, IRIA, Rocquencourt, France, October 1978; to appear in D. Lanciaux, Ed, *Operating Systems*, North-Holland.

[Kahn]

Kahn, R. E.: "Resource-sharing computer communication networks," *Proc. IEEE*, 60(11):1397-1407, November 1972.

[Kay77]

Kay, A.: "Microelectronics and the personal computer," *Scientific American*, 237(3):230-244, September 1977.

[Kay78]

Kay, A.: "Programming your own computer," *Science Year, The World Book Science Annual, 1979*, World Book-Childcraft International, Inc., Chicago, 1978.

[Kay-Goldberg]

Kay, A., and A. Goldberg: "Personal dynamic media," *Computer*, 10(3):31-41, March 1977.

[Lampson-Sproull]

Lampson, B. W. and R. F. Sproull: "An open operating system for a single-user machine," *Operating Systems Review* 13(5), November 1979.

[Lampson-Sturgis]

Lampson, B. W. and H. E. Sturgis: "Crash recovery in a distributed data storage system," to appear in *Comm. ACM*.

[Levin-Schroeder]

Levin, R., and M. D. Schroeder, "Transport of electronic messages through a network," CSL 79-4, Xerox Palo Alto Research Center, 1979.

[McDaniel]

McDaniel, G.: "METRIC: a kernel instrumentation system for distributed environments," *Operating Systems Review* 11(5):93-99, November 1977.

[Metcalf-Boggs]

Metcalf, R. M. and D. R. Boggs: "ETHERNET: distributed packet switching for local computer networks," *Comm. ACM*, 19(7):395-404, July 1976.

[Mitchell *et al*]

Mitchell, J. G., W. Maybury, and R. E. Sweet: *Mesa Language Manual*, CSL 79-5, Xerox Palo Alto Research Center, 1979.

[Morris]

Morris, J. H.: personal communication.

[Newman-Sproull]

Newman, W. M. and R. F. Sproull: *Principles of Interactive Computer Graphics*, second edition, McGraw-Hill, 1979.

[Richards]

Richards, M.: "BCPL: a tool for compiler writing and system programming," *AFIPS Conf. Proc.* (SJCC) 35:557-566, 1969.

[Ritchie]

Ritchie, D. M., S. C. Johnson, M. E. Lesk, and B. W. Kernighan: "The C programming language," *Bell Syst. Tech. J.*, 57(6):1991-2019, July-August 1978.

[Shoch]

Shoch, J. F.: "An overview of the programming language Smalltalk-72," *Convention Informatique*, Paris, 1977; to be reprinted in *SIGPLAN Notices*, 1979.

[Shoch-Hupp]

Shoch, J. F., and J. Hupp: "Performance of an Ethernet local network--a preliminary report," *Proc. Local Area Communication Network Symp.*, NBS, Boston, May 1979.

[Sproull]

Sproull, R. F.: "Raster graphics for interactive programming environments," to appear in *Computer Graphics*, also available as CSL-79-6, Xerox Palo Alto Research Center, June 1979.

[Swinehart *et al*]

Swinehart, D. C., G. McDaniel, and D. R. Boggs: "WFS: a simple shared file system for a distributed environment," *Operating Systems Review* 13(5), November 1979.

[Teitelman77]

Teitelman, W.: "A display-oriented programmer's assistant," *Proc. 5th Int. Joint Conf. Artificial Intelligence*, 1977, pp. 905-917.

[Teitelman78]

Teitelman, W.: *Interlisp Reference Manual*, Xerox Palo Alto Research Center, October 1978.

XEROX

XEROX

Alto: A personal computer By G. P. Thacker, E. M. McCreight, B. W. Lampson, R. F. Sproull, and D. H. Boggs

Xerox Corporation
Palo Alto Research Center
3333 Coyote Hill Road
Palo Alto, California 94304

XEROX® is a trademark of XEROX CORPORATION Printed in U S A

CSL-79-11